

**Portable drilling solutions to speed up  
Fabrication, Installation & Maintenance**

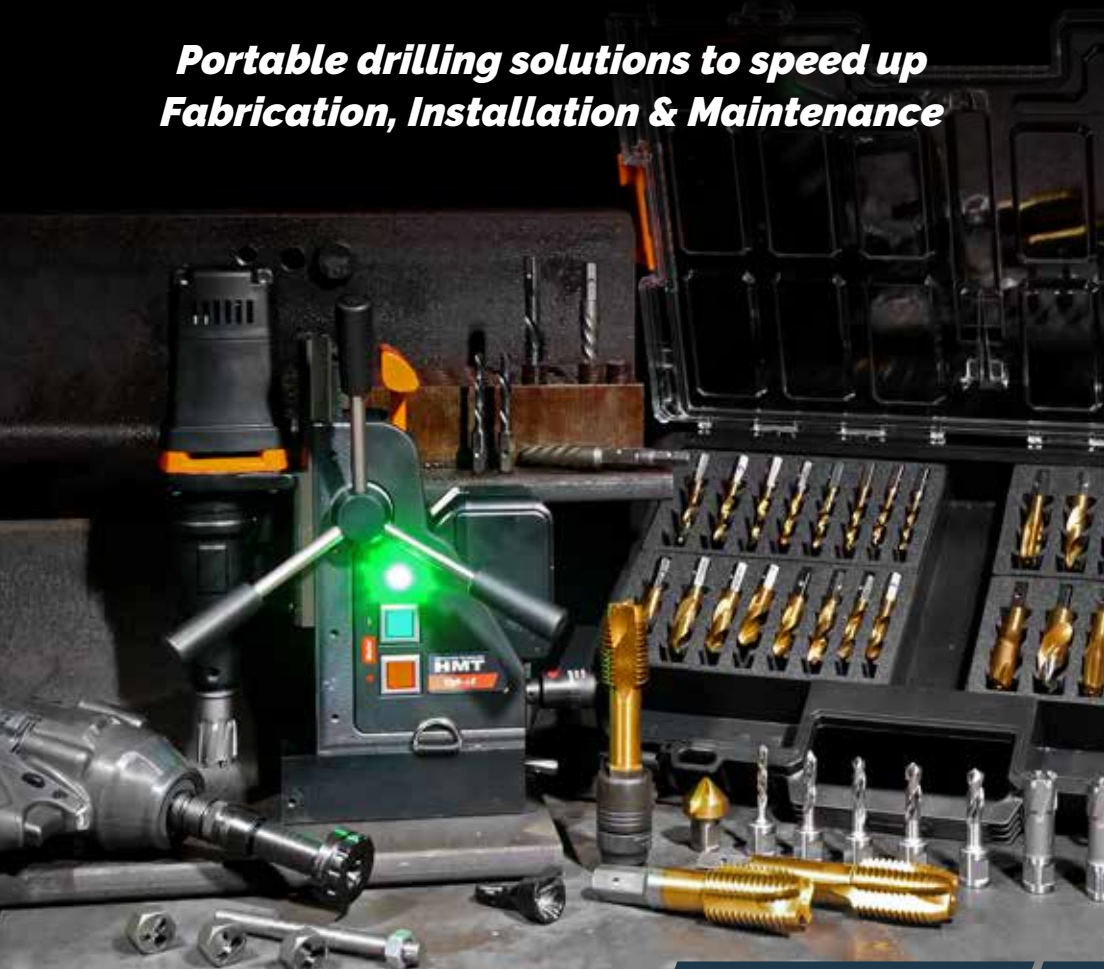

**VERSADRIVE<sup>®</sup>**  
PATENT PROTECTED

Featuring over 100 new products including  
the NEW compact V36-18 Cordless Magdrill

**VERSADRIVE<sup>®</sup> Cutting Tools** P18

**CARBIDEMAX<sup>®</sup> Cutters** P60

**ULTRA<sup>®</sup> Cutting Tools** P68

**HMT Magnetic Drills** P74

**STAKIT Modular Storage** P96



## OUR STORY

*10 years ago, we studied the market to find out how to make a meaningful difference, and this study revealed 3 crucial insights:*

- Firstly, that steel is rapidly emerging as the most sustainable & reusable construction material
- Secondly, steel components hold the industrial world together.
- Finally, that there was a huge hidden pain point around making and modifying the connection holes that fasten these components together.

This realisation launched HMT as a new company dedicated to cutting tool innovation to speed up metalworking.

HOLEMAKER TECHNOLOGY  
**HMT**

## WHAT WE DO

*HMT is a specialist manufacturer of portable cutting and drilling solutions*

We are based in the UK with a worldwide network of independent stockist dealers.

For 2024 we have reached the milestone of our 10th anniversary.

It's been a decade of growth powered by teamwork, innovation, and commitment behind the scenes, that has steadily shaped HMT into an industry player.

HMT and **VERSADRIVE**<sup>®</sup> products now are specified by some of the world's leading industrial engineering companies including Siemens, Vestas, BAE Systems, EDF Energy & Babcock.

HOLEMAKER TECHNOLOGY  
**HMT**



## KEY POINT OF DIFFERENCE



*Our key point of difference is the unique and patented product range that gives the following benefits*



### - **PRODUCTIVITY**

15x faster than traditional methods



### - **SAFETY**

Impact rated system stops dangerous kickback when drilling



### - **STANDARDISATION**

Modular system provides more solutions from fewer tools



HOLEMAKER TECHNOLOGY  
**HMT**



## KEY POINT OF DIFFERENCE



*Our point of difference is not only the products, but also how our support systems optimise the value that HMT provides:*



- Field-based sales demonstrator team who make joint visits with our dealers

- The unique MATLAST warranty support system



- Extensive marketing and training resources



- 95% stock availability for sameday shipping



HOLEMAKER TECHNOLOGY  
**HMT**





## OUR MISSION & VISION



### **HMT Mission:**

To speed up metalworking through cutting tool innovation



### **HMT Vision:**

Becoming the leading brand of portable cutting tools



HOLEMAKER TECHNOLOGY  
**HMT**



## OUR VALUES



### **The 5 HMT Values:**

#### **Innovate**

Constantly finding new ways to save time, add value and solve problems



#### **Specialise**

A laser-like focus on portable cutting tool solutions for the metalworking industry



#### **Optimise**

Always improving our effectiveness and efficiency



#### **Be Agile**

Moving fast to overcome any challenges and meet any new opportunities



#### **Be Nice**

Being a great team to work with

# VERSADRIVE®

## The Worlds 1st Impact-Rated modular cutting tool system

Unique, patented range of Impact rated tooling to speed up making and modifying holes in metal components.

**VERSADRIVE®** by Holemaker Technology is the 1st modular cutting system in the world that allows cutting tools to be used with Impact Wrenches and Impact Drivers as well as Rotary drills like Magnet Drills, Hand-Held drills and Pillar drills.

This innovative system features a range of Impact rated cutting tools as well as a collection of specially designed and custom engineered adapters to rapidly fit cutting tool to power tool, with fast tool changeover, giving over 2000 solutions.

Tools in the range have also been specifically designed and developed to outperform and outlast the closest comparable products.

With quicker cut time, longer life and more holes per product **VERSADRIVE®** tools save time, money & increase productivity.

## Contents

VersaDrive® Adapters P.18-21

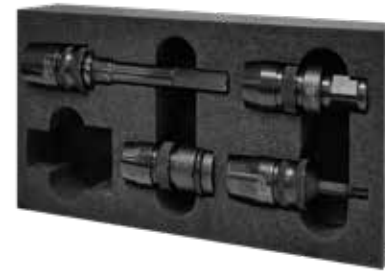

ImpactaDie Die Threader & ImpactaBurr P.24-25



VersaDrive® Impact Step Drills & Reamers P.30-35



VersaDrive® DrillSinks & Countersinks P.48-51



ImpactaBite Bolt Extractor System P.22-23



VersaDrive® Cobalt & TurboTip Drill Bits P.26-29



VersaDrive® ImpactaTaps & Impact Drill Taps P.36-47



VersaDrive® MAX Impact Reamers & Taps P.52-55



# CARBIDEMAX<sup>®</sup>

**A new generation of cutting solutions giving 10X longer life while reducing cut time**

**CARBIDEMAX<sup>®</sup>** TCT cutters offer a life expectancy up to 10x that of standard HSS cutters and cutting speeds up to 64% faster thanks to their premium Tungsten Carbide cutting teeth and advanced triple-cut tool geometry.

Increase productivity and halve the cost of hole broaching.

**CARBIDEMAX<sup>®</sup>** HoleCutters are a unique, heavy duty TCT holesaw with an unrivalled cutting depth.

Use in a cordless rotary drill to replace a magnetic drill where job space is restricted - outlast traditional holesaws by 15X.

## Contents

CarbideMax<sup>®</sup> HoleCutters P.56-59

CarbideMax<sup>®</sup> 40 & 55 TCT Broach Cutters P.60-61



CarbideMax<sup>®</sup> 80 & 110 TCT Broach Cutters P.62-63

CarbideMax<sup>®</sup> 150 & 200 TCT Broach Cutters P.64-65



CarbideMax<sup>®</sup> XL55 & XL110 TCT Cutters P.66-67

CarbideMax<sup>®</sup> MultiSink & Countersinks P.89-91



Accessories P.92-93

Tungsten Carbide Burrs & Cutting Lubricant P.94-95





# ULTRA

**HMT have developed a generation of ULTRA cutting tools for use in the most challenging applications**

Specialist high performance range of tooling for wear plate, armor applications and rail track applications.

Premium, long-life tooling for use in the most challenging applications.

The specialist **ULTRA** coating is proven to significantly increase tool life, making these tools the ideal solution in situations requiring high performance durability, prolonged use or machining extremely hard materials.

They are produced from premium grade materials and coated using a range of state of the art, high-temperature surface coatings.

**Rated for use on materials such as**

HARDOX - CREUSABRO - ABRO - RAEX  
STRENX - BISALLOY

## Contents

STAKIT ULTRA Hardox Kit P.68



ULTRA Weldon Countersink & MultiSink P.68-69



ULTRA 55 & 110 TCT Broach Cutters P.70-71



ULTRA Coated Twist Drill Bits & Set P.72



Straight Flute TCT Cutters P.73



ULTRA Straight Flute TCT Cutters P.73



Cordless Coolant Pump System P.86



Specialist Countersinks P.90-91

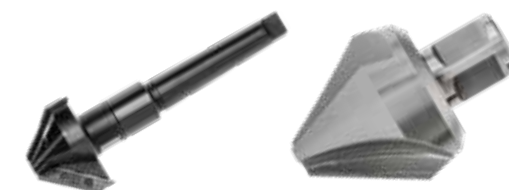

# MAGNETIC DRILLS

**Unique benefits from the most comprehensive range of magnetic drilling systems on the market**

From the lightest, most compact cordless machine on the market to machines with variable speed, variable torque and forward/reverse as standard, Holemaker Technology's advanced magnetic drills have been custom engineered to optimise performance.

Designed and hand-built in our Sheffield factory by the expert HMT team, all machines with tapping capacity are powered by a legendary Eibenstock motor.

All machines are supplied with both a weldon adapter and **VERSADRIVE**® adapter to give immediate interchangeability with the patented **VERSADRIVE**® modular cutting tools.

2 Year warranty when registered online.

## Contents

V35 Compact & V36 Cordless Mag Drills P.74-75



RTQ40 Low Profile & V50 Mag Drills P.76-77



V35 & V60T Pipe Magnet Drills P.78-79



V60T & V85T Magnet Drills P.80-81



V100T & V125T Magnet Drills P.82-83



MAX150T & MAX200T Magnet Drills P.84-85



Cordless Coolant Pump System P.86



OverReach System P.87





# STAKIT®

**STAKIT is a new modular system of robust stacking site kits to help transport, protect and organise your VERSADRIVE® tooling & power tools to the workplace**

Modular, clip-together system so you can plug and play to choose the right package for your needs, or to start small and add more kits over time.

Each case can be used individually or interlocked for fast use in the field, on the jobsite or in the workshop.

Tough enough for use in the field and jobsite, being designed to be damage resistant, dustproof and weatherproof.

**STAKIT** is complemented by the **InsertFoam** system of foam tool set cases. All HMT and **VERSADRIVE**® sets are supplied in InsertFoam packaging in sizes which readily fit the STAKIT ETOP cases.

Bespoke and customisable sets are readily available.

## Contents

ImpactaBite & VersaDrive MAX Reamer Sets P.23&54



STAKIT Customisable Empty ETOP Top Cases P.96



STAKIT InsertFoam Customisable Empty Foam Inserts P.97



STAKIT InsertFoam Kitted Sets P.98-103



STAKIT ETOP2 Impact Starter Kit & TurboTip Kit P.104



STAKIT ETOP4 Starter Kit & Reamer Kit P.105



STAKIT Steel Erector's Snagging Kit & SiteCart P.106



STAKIT Site Installation Kit & Install SiteKits P.107-111



VersaDrive® adapters have been custom engineered to rapidly fit VersaDrive® cutting tools to a wide range of standard site and workshop drive tools, including Impact Wrenches, Magnet Drills and cordless Combi Drills.

This unique system means that VersaDrive® tooling offers the greatest flexibility of use of any metal cutting tools as it can be used with almost any power tool using cordless, mains or air power.



### FEATURES & BENEFITS

- Rapid-Lock, single handed loading
- Quick Release collar for swift tool changeover
- Impact rated for high speed operation - up to 15x faster than traditional methods
- Impact rated system stops dangerous kickback when drilling with handheld drills
- Knurled design for easy grip in damp and greasy conditions
- Collar design prevents contact with work piece and accidental tool release
- Hardened steel components with rust resistant finish
- Industrial strength to easily handle the high torque of modern Impact tools
- Converts a wide range of powertools for use with VersaDrive®

## VersaDrive® Rapid-Lock Adapter Set

NEW

Small InsertFoam to fit **STAKIT** ETOP2 or ETOP4 top cases - See page 96-97

### Contains:

- ¼" VersaDrive® Impact Driver Adapter
- ½" VersaDrive® Impact Wrench Adapter
- VersaDrive® Magnet Drill Weldon Adapter
- VersaDrive® 130mm Extension Arbor

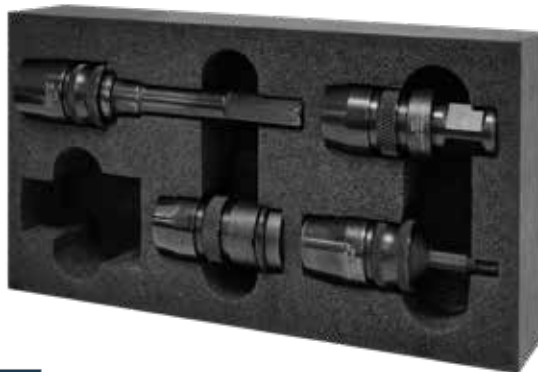

Part No	Product
111005-SET1	VersaDrive® Rapid-Lock Adapter InsertFoam Set 4pc

### VersaDrive® Rapid-Lock ¼" Impact Driver Adapter



Converts standard ¼" Impact Drivers for use with VersaDrive®

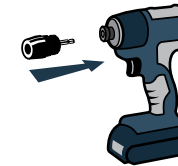

Part No	Ø (mm)	L (mm)
111027-014A	28	75

### VersaDrive® Rapid-Lock ½" Impact Wrench Adapter



Rapid-Lock VersaDrive® adapter to convert ½" Impact Wrenches for use with VersaDrive®

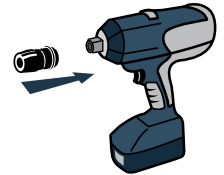

Supplied with retention pin & securing ring

Part No	Ø (mm)	L (mm)
111130-012A	28	55

### VersaDrive® Rapid-Lock Magnet Drill Adapter



Converts Magnet Drills for use with VersaDrive®

Fits all standard Magnet Drills with 19.05mm (¾") Weldon arbor

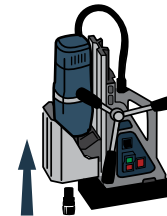

Part No	Ø (mm)	L (mm)
111035-01	28	66

### VersaDrive® Rapid-Lock Extension Arbor 130mm

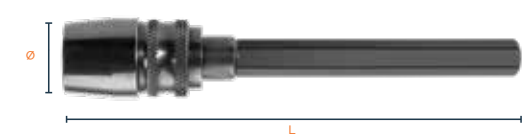

Extends working reach of all VersaDrive® tools & bypasses obstacles

Can be used in conjunction with other VersaDrive® adapters  
11mm Hex shank for non-slip use in drill chucks  
Rated for Impact and Rotary use

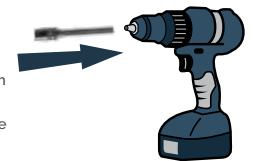

Part No	Ø (mm)	L (mm)
111015-130	28	130

## VersaDrive® Rapid-Lock Extension Arbor 300mm



Extends working reach of all VersaDrive® tools & bypasses obstacles  
Can be used in conjunction with other VersaDrive® adapters  
11mm Hex shank for non-slip use in drill chucks  
Rated for Impact and Rotary use

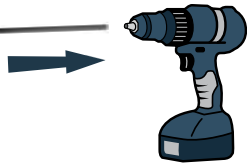

Part No	Ø (mm)	L (mm)
111015-300	28	300

## VersaDrive® Rapid-Lock SDS+ Adapter



Converts standard SDS+ Drills for use with VersaDrive® (Use in Rotary mode only)

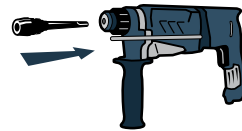

Part No	Ø (mm)	L (mm)
112010-01	28	140

## VersaDrive® Heavy Duty 3/8" Impact Wrench Adapter



Heavy Duty VersaDrive® adapter to convert high-power 3/8" Impact Wrenches for use with VersaDrive®

Rust resistant Manganese Phosphate finish

Supplied with retention pin & securing ring

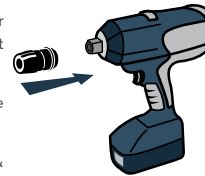

Part No	Ø (mm)	L (mm)
111120-038A	25	50

## VersaDrive® Heavy-Duty 1/2" Impact Wrench Adapter



Heavy Duty VersaDrive® adapter to convert high-power 1/2" Impact Wrenches for use with VersaDrive®

Rust resistant Manganese Phosphate finish

Supplied with retention pin & securing ring

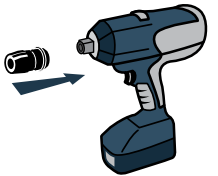

Part No	Ø (mm)	L (mm)
111120-012A	25	55

## VersaDrive® Rapid-Lock Morse Taper Arbor



Ideal for workshop use with Morse Taper Pillar Drills & Magnet Drills

Available in Morse Taper 2 & 3

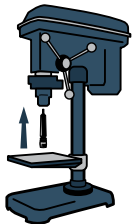

Part No	Drive	Ø (mm)	L (mm)
111045-02	MT2	28	130
111045-03	MT3	28	147

## VersaDrive® Magnet Drill Adapter - 19.05mm



Converts Magnet Drills for use with VersaDrive®

Recommended for use drilling very hard materials when high precision with minimal runout is required

Fits all standard Magnet Drills with 19.05mm (3/4") Weldon arbor

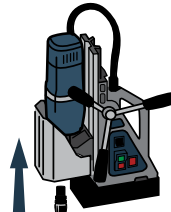

Part No	Ø (mm)	L (mm)
111030-0002	26	60.5

## VersaDrive® Heavy Duty 3/4" Impact Wrench Adapter



Heavy Duty VersaDrive® adapter to convert high-power 3/4" Impact Wrenches for use with VersaDrive®

Rust resistant Manganese Phosphate finish

Supplied with retention pin & securing ring

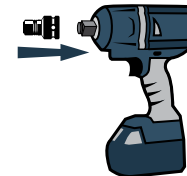

Part No	Ø (mm)	L (mm)
111120-034A	38	60

## VersaDrive® Heavy Duty Adapter Set 4pc



Small InsertFoam to fit **STAKIT** ETOP2 or ETOP4 top cases.

**Contains:**  
VersaDrive® 1/2" Heavy Duty Impact Wrench Adapter  
VersaDrive® 3/4" Heavy Duty Impact Wrench Adapter  
VersaDrive® Rapid-Lock Magnet Drill Adapter  
VersaDrive® 130mm Extension Arbor

Part No	Size
111005-SET2	VersaDrive® HD Adapter InsertFoam Set 4pc



## ImpactaBite Left Hand Drill Bits

NEW

VERSADRIVE®  
PATENT PROTECTED

Premium specification drill bits with left-handed spiral flute. 8% Cobalt with advanced TiAlN coating to reduce friction and heat generation. Can be used both on Rotary and Impact settings.

To be used for drilling the pilot holes in broken bolts and seized studs ready for VersaDrive® Bolt extractors. Designed to run in reverse to help loosen the seized item at the same time as creating the pilot hole.



### FEATURES & BENEFITS

- Premium 8% Cobalt with advanced TiAlN coating
- For use on hardened bolts & studs
- Loosen seized bolts
- Impact Rated for high speed operation
- Drill pilot holes ready for ImpactaBite bolt extractors to be inserted
- VersaDrive patented shank & adapters provide multiple modular solutions
- Use on impact to prevent dangerous kickback caused by handheld rotary tools

FOR DETAILED TECHNICAL ADVICE & RPM GUIDANCE SEE P.112

Part No.	Pilot Drill No.	Use with bolt sizes	Use with bolt sizes	L1	L
209011-030	3	M5 - M6	7/32 - 9/32"	47mm (1-27/32")	87mm (3-27/64")
209011-040	4	M8 - M10	5/16 - 3/8"		
209011-050	5	M12 - M14	1/2 - 9/16"		
209011-060	6	M16 - M20	5/8 - 3/4"		
209011-070	7	M22 - M26	7/8 - 1-1/8"		

### NEW Pilot Drill & Bolt Extractor Combination Set

#### Contents:

4 x ImpactaBite Left Hand Pilot Drill Bits #3, #4, #5, #6  
4 x ImpactaBite Bolt Extractors #3, #4, #5, #6



2040EX-SET1	8 pcs	Extract bolts M5 - M20 & 7/32 - 7/8"
-------------	-------	---

InsertFoam Sets are compatible with STAKIT ETOP2 & ETOP4 cases - sold separately - Page 96

## ImpactaBite Bolt Extractors

NEW

VERSADRIVE®  
PATENT PROTECTED

Extract broken bolts and seized studs with the new VersaDrive® impact rated bolt extractor. A vast improvement to using traditional hand operated easy-outs.

ImpactaBite uses the impact feature to break the grip caused by corroded or damaged threads.

Use once the pilot holes have been created with ImpactaBite Left Hand Drill Bits.



### FEATURES & BENEFITS

- Extract seized bolts and studs easily
- Impact Rated for high speed operation
- Solid one piece steel design for heavy duty applications
- Heavy-duty hex shank design for secure non-slip operation
- VersaDrive patented shank & adapters provide multiple modular solutions
- Use on impact to prevent dangerous kickback caused by handheld rotary tools

FOR DETAILED TECHNICAL ADVICE & RPM GUIDANCE SEE P.112

Part No.	Bolt Extractor No.	Use with bolt sizes	Use with bolt sizes	L1 (mm)	L (mm)
403010-030	3	M5 - M6	7/32 - 9/32"	25	65
403010-040	4	M8 - M10	9/32 - 3/8"	35	74
403010-050	5	M12 - M14	3/8 - 5/8"	39	77
403010-060	6	M16 - M20	5/8 - 7/8"	46	84
403010-070	7	M22 - M26	7/8 - 1-1/8"	49	90

### NEW STAKIT Pilot Drill & Bolt Extractor ETOP2 Set

#### Contents:

5 x ImpactaBite Left Hand Pilot Drill Bits #3, #4, #5, #6, #7  
5 x ImpactaBite Bolt Extractors #3, #4, #5, #6, #7  
1 x VersaDrive® Rapid-Lock 1/2" Impact Wrench Adapter  
1 x VersaDrive® Rapid-Lock Magnet Drill Adapter  
1 x VersaDrive® STAKIT ETOP2 Half Top Case

2040EX-SET2	12 pcs	Extract bolts M5 - M26 & 7/32 - 1-1/8"
-------------	--------	---



# ImpactaDie Impact Die Threader

NEW

**VERSADrive®**  
PATENT PROTECTED

Create external threads quickly and easily with this unique patent-pending impact die system.

Ideal for both creating/extending new threads, repairing existing damaged/deformed threads or cleaning old threads clogged with surface coatings, rust or other unwanted material that can prevent threads mating and turning properly.

The guide collar system ensures that the thread cutting process runs straight and true. Once a thread is established, the flush type collar can be used.

Patent Pending GB 2319619.9



## FEATURES & BENEFITS

- Guided threading for straight & true results
- Create external threads up to 50mm long
- Impact Chipbreaker action for effective swarf evacuation
- VersaDrive patented shank and modular adapters provide unbeatable jobsite flexibility
- Impact-rated due to dual hardening process - allows up to 15X faster speed than traditional methods
- Use with Impact Wrenches
- Clean out existing external threads
- Use on Impact to prevent dangerous kickback

## IMPACTADIE WITH GUIDE COLLAR & GUIDE 115100-050 - FOR CREATING THREADS

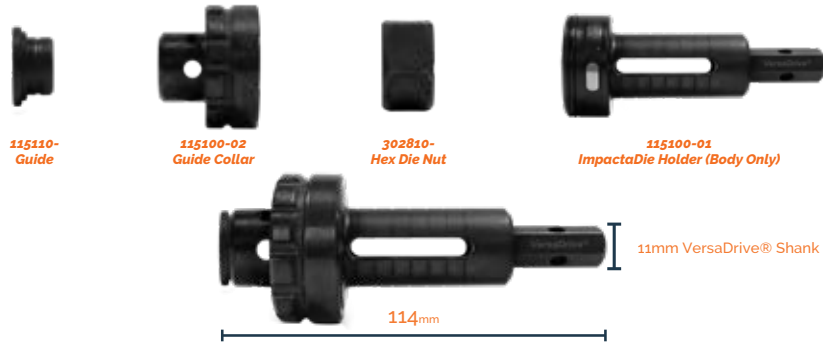

## IMPACTADIE WITH FLUSH COLLAR 115100-060 - FOR CLEANING & REPAIRING THREADS



Part No.	Product
115100-050	VersaDrive® ImpactaDie Holder & Guide Collar (Guides sold separately)
115100-060	VersaDrive® ImpactaDie Holder & Flush Collar

Replacement parts available to purchase on request:  
ImpactaDie Holder (115100-01) // Guide Collar (115100-02) // Flush Collar (115100-03)

Part No.	ImpactaDie 24mm Hex Die Nut
302810-0060	M6 x 1.0
302810-0080	M8 x 1.25
302810-0100	M10 x 1.50
302810-0120	M12 x 1.75



Part No.	ImpactaDie 24mm Hex Die Nut
302820-0010	1/4-20 UNC
302820-0020	5/16-18 UNC
302820-0030	3/8-16 UNC
302820-0040	1/2-13 UNC

Part No.	ImpactaDie Guide
115110-0060	M6
115110-0080	M8
115110-0100	M10
115110-0120	M12



Part No.	ImpactaDie Guide
115120-0010	1/4"
115120-0020	5/16"
115120-0030	3/8"
115120-0040	1/2"

## STAKIT Sets

115810-SET	ImpactaDie Kit c/w ImpactaDie holder, Guide Collar, Flush Collar, M6/8/10/12 Guides. M6/8/10/12 Hex Die Nuts + ImpactaBurr Chamfer Tool
115820-SET	ImpactaDie Kit c/w ImpactaDie holder, Guide Collar, Flush Collar, 1/4, 5/16, 3/8, 1/2" UNC Guides. 1/4, 5/16, 3/8, 1/2" UNC Hex Die Nuts + ImpactaBurr Chamfer Tool



# ImpactaBurr TCT Chamfer Tool

NEW

The ImpactaBurr chamfer tool has tungsten carbide inserts designed to chamfer the outside edge of tube and round bar.

This removes dangerous burrs and also prepares the facing edge ready to receive an external thread or fastener.

- Quick and effective deburring and chamfering
- Impact rated to reduce dangerous kickback
- Compatible with the VersaDrive® adapter range
- For use with 4 - 18mm bar, fasteners or studding
- 60° angle
- Impact & Rotary rated



Part No.	Product	Ø	L
115200-0190	ImpactaBurr TCT Chamfer Tool 19mm	29mm	57mm

11mm VersaDrive® Shank

# VersaDrive® TurboTip Drill Bits

**VERSADRIVE®**  
PATENT PROTECTED

VersaDrive® TurboTip Impact drill bits are stepped tip bits that drill at twice the speed of standard bits without the need for pilot drilling while cutting a perfectly round hole.

Turbocharge your drilling performance by using this revolutionary tool with an Impact Wrench or Impact Driver. Double hardened and titanium coated for faster drilling & reduced wear.

VersaDrive® TurboTip drill bits have a patented non-slip, Hex shank suitable for use in any standard 1/2" drill chuck for cordless or Pistol Drills or used with a VersaDrive® Rapid Lock adapter for use in a wide range of powertools such as Magnetic Drills.



## FEATURES & BENEFITS

- No pilot drilling needed due to patented stepped-tip drill point
- Faster drilling with 1/3 less feed pressure required, reducing fatigue for the operator
- Industrial grade Titanium Nitride coating reduces heat buildup and burn-out
- Use on Impact to prevent dangerous kickback caused by handheld rotary tools
- Heavy-duty hex shank design for secure non-slip operation
- Quality results on stainless steels and Inox - rotary application recommended
- VersaDrive patented shank and modular adapters provide unbeatable jobsite flexibility
- Impact-rated due to dual hardening process - allows up to 15X faster speed than traditional methods

**FOR DETAILED TECHNICAL ADVICE & RPM GUIDANCE SEE P.115**

Watch the video



## POWERTOOL RECOMMENDATIONS ON MILD STEEL

**Impact Drivers**  
Optimal performance: Up to 10mm  
Adapter P.19

**Impact Wrenches**  
Optimal performance: Up to 14mm  
Possible use up to 22mm  
Adapter P.19

**Magnetic Drills**  
Optimal performance: Up to 16mm  
Possible use up to 22mm  
Adapter P.19

**Cordless Drills**  
Optimal performance: Up to 12mm

**SDS+ Drills (Rotary only mode)**  
Optimal performance: Up to 14mm  
Adapter P.20

**Pillar Drills**  
Optimal performance: Up to 22mm  
Adapter P.20

**Recommended Powertool**

**Impact Wrench**

Metric	ØD (mm)	Tap Size
209015-0060	6	
209015-0068	6.8	M8
209015-0070	7	
209015-0080	8	
209015-0085	8.5	M10
209015-0090	9	
209015-0100	10	
209015-0105	10.5	M12
209015-0110	11	
209015-0120	12	M14
209015-0130	13	
209015-0140	14	M16
209015-0160	16	
209015-0180	18	
209015-0200	20	
209015-0220	22	

Inch	ØD (")	ØD (mm)	Tap Size (UNC)
209016-0010	3/16	4.8	
209016-0020	#7	5.1	1/4-20
209016-0030	7/32	5.6	
209016-0040	1/4	6.4	
209016-0050	#F	6.6	5/16-18
209016-0060	9/32	7.1	
209016-0070	5/16	7.9	3/8-16
209016-0080	11/32	8.7	
209016-0090	3/8	9.5	
209016-0100	27/64	10.7	1/2-13
209016-0120	7/16	11.1	
209016-0130	1/2	12.7	
209016-0140	17/32	13.5	5/8-11
209016-0150	9/16	14.3	
209016-0160	5/8	15.9	
209016-0170	11/16	17.5	
209016-0180	3/4	19.05	
209016-0190	13/16	20.6	

## InsertFoam Sets

209015-SET1	6, 8, 10, 12mm
209015-SET2	6, 7, 8, 9, 10, 11, 12mm
209015-SET3	6.8, 8, 8.5, 10, 10.5, 12, 14mm
209015-SET4	6, 8, 10, 12, 14, 18 & 22mm
209015-SET6	6, 6.8, 7, 8, 8.5, 9, 10, 10.5mm
209015-SET7	11, 12, 13, 14, 16, 18, 20mm
209016-SET1	3/16, 1/4, 5/16, 1/2"
209016-SET2	#7, F, 5/16, 27/64
209016-SET3	17/32, 9/16, 5/8, 11/16, 3/4, 13/16"

InsertFoam Sets are compatible with STAKIT ETOP2 & ETOP4 cases - sold separately - Page 96

**VERSADRIVE®**  
PATENT PROTECTED

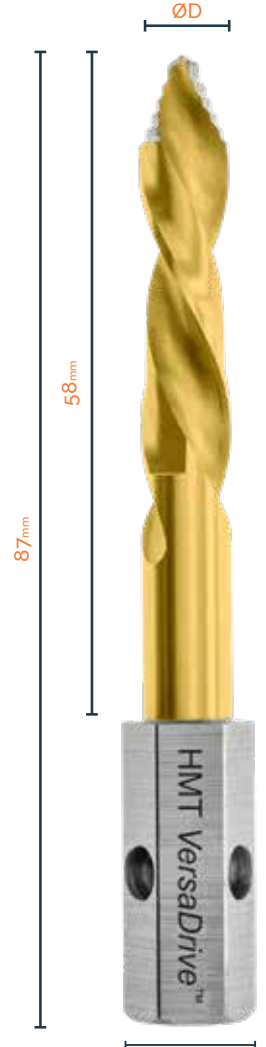



# VersaDrive® Cobalt Drill Bits

**VERSADRIVE®**  
PATENT PROTECTED

VersaDrive® Cobalt Drills are a premium grade 8% Cobalt drill bit with fully ground flutes, 135° Split point and Titanium coating for faster drilling & reduced wear.

Suitable for heavy fabrication use, this Cobalt drill bit can also be used to drill stainless steel, mild steel, cast iron and a wide range of other structural materials.

VersaDrive® Drill Bits have a patented non-slip, Hex shank suitable for use in any standard 1/2" drill chuck for cordless or Pistol Drills or used with a VersaDrive® Rapid Lock adapter for use in a wide range of powertools such as Magnetic Drills.



## FEATURES & BENEFITS

- Precision ground flute design provide easy chip clearance
- 8% Cobalt tool steel for long life & endurance with 135° split point for easy starting & high accuracy
- Industrial grade Titanium Nitride coating reduces heat buildup and burn-out
- Use on Impact to prevent dangerous kickback caused by handheld rotary tools
- Heavy-duty hex shank design for secure non-slip operation
- Quality results on stainless steels and Inox - rotary application recommended
- VersaDrive patented shank and modular adapters provide unbeatable jobsite flexibility
- Impact-rated due to dual hardening process - allows up to 15X faster speed than traditional methods

Watch the video



**FOR DETAILED TECHNICAL ADVICE & RPM GUIDANCE SEE P.114**

## POWERTOOL RECOMMENDATIONS ON MILD STEEL

**Impact Drivers**  
Possible use up to 10.5mm  
Adapter P.19

**Impact Wrenches**  
Possible use up to 10.5mm  
Adapter P.19

**Magnetic Drills**  
Optimal performance: Up to 16mm  
Possible use up to 22mm  
Adapter P.19

**Cordless Drills**  
Optimal performance: Up to 14mm  
Possible use up to 22mm  
Adapter P.20

**SDS+ Drills (Rotary only mode)**  
Possible use up to 14mm  
Adapter P.20

**Pillar Drills**  
Optimal performance: Up to 22mm  
Adapter P.20

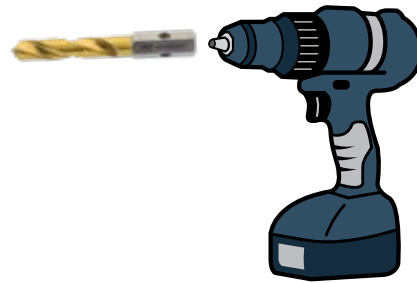

## Recommended Powertool

**Cordless Drill**

Metric	ØD (mm)	Tap Size
209010-0042	4.2	M5*
209010-0050	5	M6*
209010-0055	5.5	-
209010-0060	6	-
209010-0065	6.5	-
209010-0068	6.8	M8*
209010-0070	7	-
209010-0075	7.5	-
209010-0080	8	-
209010-0085	8.5	M10*
209010-0090	9	-
209010-0095	9.5	-
209010-0100	10	-
209010-0102	10.2	M12*
209010-0105	10.5	-
209010-0115	11.5	-
209010-0120	12	M14*
209010-0125	12.5	-
209010-0130	13	-
209010-0140	14	M16*
209010-0155	15.5	M18*
209010-0160	16	-
209010-0175	17.5	M20*
209010-0180	18	-
209010-0200	20	-
209010-0210	21	M24*
209010-0220	22	-
Inch	ØD (")	Tap Size
209013-0010	3/16	-
209013-0020	#7	1/4-20
209013-0030	7/32	-
209013-0040	1/4	-
209013-0050	#F	5/16
209013-0060	9/32	-
209013-0070	5/16	3/8
209013-0080	11/32	-
209013-0090	3/8	-
209013-0100	27/64	1/2
209013-0120	7/16	-
209013-0130	1/2	-
209013-0140	9/16	-
InsertFoam Sets		
209010-SET1	6, 8, 10, 12mm	-
209010-SET2	5, 6.8, 8.5, 10.2mm	-
209010-SET3	5, 6, 6.8, 8, 8.5, 10, 10.2mm	-
209010-SET4	12, 13, 14, 16, 18, 20, 22mm	-
209010-SET6	5, 6, 6.8, 7, 7.5, 8, 9, 10mm	-
209010-SET7	10.2, 11.5, 12, 13, 14, 16, 18mm	-
209013-SET1	1/4, 5/16, 3/8, 1/2"	-
209013-SET2	#7, #F, 5/16, 3/8"	-
209013-SET3	#7, 1/4, #F, 5/16, 3/8, 27/64, 1/2"	-
209013-SET4	3/16, 1/4, 5/16, 3/8, 27/64, 7/16, 1/2, 9/16"	-

\* Metric Coarse

InsertFoam Sets are compatible with STAKIT ETOP2 & ETOP4 cases - sold separately - Page 96

**VERSADRIVE®**  
PATENT PROTECTED

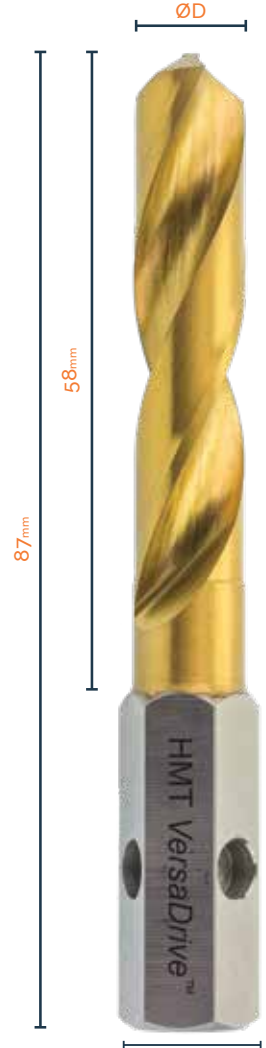

11mm VersaDrive® Shank



# VersaDrive® Impact Step Drills

**VERSADRIVE®**  
PATENT PROTECTED

The first step drill optimised for use with Impact Wrenches & Impact Drivers allowing the user to create holes in seconds.

Featuring a spiral flute design with self-starting drill tip, for fast, smooth drilling with a rotary drill or Impact Wrench and market leading 5mm thick drilling capacity.

VersaDrive® Step Drills have a patented non-slip, Hex shank suitable for use in any standard 1/2" drill chuck for cordless or Pistol Drills or used with a VersaDrive® Rapid Lock adapter for use in a wide range of powertools such as Magnetic Drills.



## FEATURES & BENEFITS

- Market leading 5mm step thickness, spiral flute design and size markings at each step
- 118° split point angle for easy hole start & pilot accuracy
- Industrial grade Titanium Nitride coating reduces heat buildup and burn-out
- Use on Impact to prevent dangerous kickback caused by handheld rotary tools
- Heavy-duty hex shank design for secure non-slip operation
- Quality results on stainless steels and Inox - rotary application recommended
- VersaDrive patented shank and modular adapters provide unbeatable jobsite flexibility
- Impact-rated due to dual hardening process - allows up to 15X faster speed than traditional methods

Watch the video



**FOR DETAILED TECHNICAL ADVICE & RPM GUIDANCE SEE P.116**

## POWERTOOL RECOMMENDATIONS ON MILD STEEL

**Impact Drivers**  
Optimal performance: Up to 30mm  
Adapter P.19

**Impact Wrenches**  
Optimal performance: Up to 30mm  
Possible up to 40mm  
Adapter P.19

**Magnetic Drills**  
Optimal performance: Up to 40mm  
Adapter P.19

**Cordless Drills**  
Optimal performance: Up to 22mm  
Possible up to 40mm

**SDS+ Drills (Rotary only mode)**  
Optimal performance: Up to 30mm  
Adapter P.20

**Pillar Drills**  
Optimal performance: Up to 40mm  
Adapter P.20

## Recommended Powertool

**Impact Wrench**

Metric	ØD (mm)	L <sub>1</sub> (mm)	L (mm)	Step Diameters (mm)
505020-0120	12	47	75	4, 6, 8, 10, 12
505020-0220	22	58	86	4, 6, 8, 10, 12, 14, 16, 18, 20, 22
505020-0300	30	77	105	4, 6, 8, 10, 12, 14, 16, 18, 20, 22, 24, 26, 28, 30
505020-0400	40	72	101	6, 8, 10, 12, 16, 18, 20, 25, 29, 32, 36, 40
Electricians Step Drill 4-32.5mm				
505040-0320	32.5	70	99	4, 6, 8.5, 10.5, 12.5, 14.5, 16, 18.5, 20.5, 23.5, 25, 30.5, 32.5
Inch	ØD (")	L <sub>1</sub> (")	L (")	Step Diameters (")
505030-0010	1/2	1-1/2	2-43/64	3/16, 1/4, 5/16, 3/8, 7/16, 1/2
505030-0020	7/8	2-9/32	3-15/32	3/16, 1/4, 5/16, 3/8, 7/16, 1/2, 9/16, 5/8, 11/16, 3/4, 13/16, 7/8
505030-0030	1-3/8	1-31/32	3 5/32	1/4, 3/8, 1/2, 5/8, 3/4, 7/8, 1, 1-1/8, 1-1/4, 1-3/8
InsertFoam Sets				
505020-SET1	12, 22, 30mm			
505020-SET2	12, 22, 30, 40mm			
505030-SET1	1/2, 7/8, 1-3/8"			

Metric Step Depth = 5mm - Except for 505020-0400 which has 6mm Step Depth  
Inch Step Depth = 3/16"

InsertFoam Sets are compatible with STAKIT ETOP2 & ETOP4 cases - sold separately - Page 96

**VERSADRIVE®**  
PATENT PROTECTED

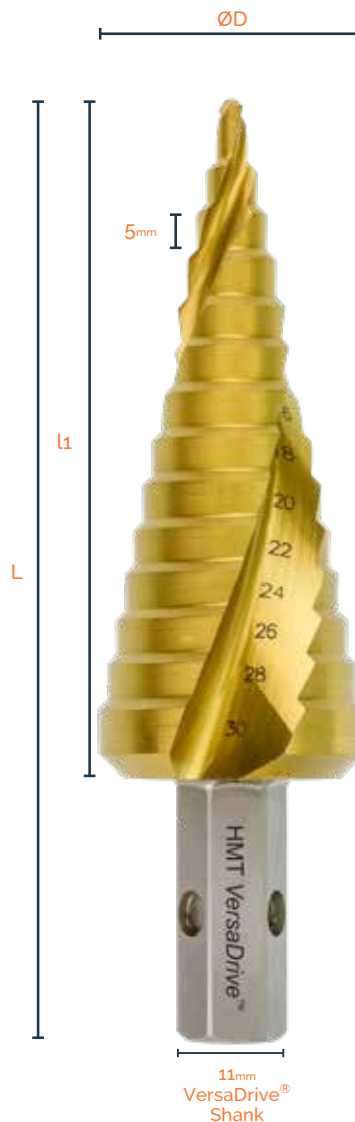

# VersaDrive® Impact Reamer

**VERSADRIVE®**  
PATENT PROTECTED

VersaDrive® reamers are the perfect hole alignment and enlarging tool for metalworkers & steel erectors for keeping the job moving when a hole is misaligned or the incorrect size for the fixing.

Featuring a specially designed 6 flute cutting geometry and Titanium coating, VersaDrive® Reamers are fully Impact rated and perform fastest when used with an Impact Wrench providing ultimate cutting performance with virtually no powertool kickback.

VersaDrive® Reamers have a patented non-slip, Hex shank suitable for use in any standard 1/2" drill chuck for Pistol Drills or used with a VersaDrive® Rapid Lock adapter for use in a wide range of powertools such as Magnetic Drills.



## FEATURES & BENEFITS

- Precision 6-flute design for smooth cutting
- Edge cutting design for hole enlargement, giving much better results than a drill bit
- Industrial grade Titanium Nitride coating reduces heat buildup and burn-out
- Use on Impact to prevent dangerous kickback caused by handheld rotary tools
- Heavy-duty hex shank design for secure non-slip operation
- Quality results on stainless steels and Inox - rotary application recommended
- VersaDrive patented shank and modular adapters provide unbeatable jobsite flexibility
- Impact-rated due to dual hardening process - allows up to 15X faster speed than traditional methods

**FOR DETAILED TECHNICAL ADVICE & RPM GUIDANCE SEE P.124**

Watch the video



## POWERTOOL RECOMMENDATIONS ON MILD STEEL

**Impact Drivers**  
Optimal performance: Up to 12mm  
Adapter P.19

**Impact Wrenches**  
Optimal performance: Up to 26mm  
Adapter P.19

**Magnetic Drills**  
Possible use Up to 26mm  
Adapter P.19

**Cordless Drills**  
Optimal performance: Up to 12mm  
Possible use Up to 14mm

**SDS+ Drills (Rotary only mode)**  
Possible use up to 12mm  
Adapter P.20

**Pillar Drills**  
Optimal performance: Up to 26mm  
Adapter P.20

**Recommended Powertool**  
**Impact Wrench**

Metric	ØD (mm)	Ød1 (mm)	L1 (mm)	L2 (mm)	L (mm)
501030-0080	8	4.5	34	68	106
501030-0100	10	6.3	34	70	108
501030-0120	12	7.5	47	103.5	142
501030-0140	14	8.5	63	106.5	144
501030-0160	16	8.5	58	114.5	152.5
501030-0180	18	10	58	121.5	171
501030-0200	20	11.6	61	136	185.5
501030-0210	21	12	61	127	178.5
501030-0220	22	13	66	136	185
501030-0240	24	15	66	137	185
501030-0260	26	16	64	135	185

Inch	ØD (")	Ød1 (")	L1 (")	L2 (")	L (")
501040-0040	1/2 (12.7mm)	19/64	1-15/16	2-1/16	5 1/2
501040-0050	9/16 (14.3mm)	9/32	2-1/16	1-15/16	5 1/2
501040-0060	5/8 (15.9mm)	5/16	2-11/64	2-21/64	6
501040-0070	11/16 (17.5mm)	3/8	2-1/4	2-1/4	6
501040-0080	3/4 (19.05mm)	13/32	2-31/64	2-33/64	7
501040-0085	13/16 (20.63mm)	15/32	2-33/64	2-31/64	7
501040-0090	7/8 (22.2mm)	17/32	2-19/32	2-13/32	7
501040-0100	15/16 (23.8mm)	19/32	2-43/64	2-21/64	7
501040-0110	1 (25.4mm)	5/8	2-43/64	2-21/64	7
501040-0120	1-1/16 (27mm)	45/64	2-9/16	2-7/16	7

## InsertFoam Sets

501030-3SET	14, 18, 22mm
501030-SET	12, 14, 18, 22, 26mm
501030-SET3	8, 10, 12, 14, 16, 18mm
501030-SET4	18, 20, 21, 22, 24, 26mm
501030-SET11	8, 10, 12, 14, 16, 18, 20, 21, 22, 24, 26mm
501040-3SET	1/2, 5/8, 3/4"
501040-5SET	1/2, 5/8, 3/4, 7/8, 1-1/16"
501040-SET7	9/16, 11/16, 13/16, 15/16, 1-1/16"

"These reamers have saved me literally hours and hours of work. They are a life saver on site"

**J3weld\_fab**  
Instagram

InsertFoam Sets are compatible with STAKIT ETOP2 & ETOP4 cases - sold separately - Page 96

**VERSADRIVE®**  
PATENT PROTECTED





# VersaDrive® ImpactaStep Cutter

**VERSADRIVE®**  
PATENT PROTECTED

The ImpactaStep Cutter offers combined drilling and reaming on materials up to 12mm thick.

Featuring 5 individual cutting diameters and a straight flute design for strength and easy resharping, the ImpactaStep Cutter is optimised for use with Impact Wrenches as well as the latest range of VersaDrive® Premium Magnet Drills.

VersaDrive® ImpactaStep Cutters have a patented non-slip, Hex shank suitable for use in any standard 1/2" drill chuck for cordless or Pistol Drills or used with a VersaDrive® Rapid Lock adapter for use in a wide range of power tools such as Magnetic Drills.



## FEATURES & BENEFITS

- 5 heavy duty drill bits in one tool - Drill new holes and enlarge holes in metal up to 12mm thick
- Safety collar prevents injury & damage when using the largest step
- Straight flute design with size markings at each step
- Industrial grade Titanium Nitride coating reduces heat buildup and burn-out
- Use on Impact to prevent dangerous kickback caused by handheld rotary tools
- Heavy-duty hex shank design for secure non-slip operation
- VersaDrive® patented shank and modular adapters provide unbeatable jobsite flexibility
- Impact-rated due to dual hardening process - allows up to 15X faster speed than traditional methods

**FOR DETAILED TECHNICAL ADVICE & RPM GUIDANCE SEE P.117**

Watch the video



## POWERTOOL RECOMMENDATIONS ON MILD STEEL

**Impact Drivers**  
Possible use  
Up to 16mm  
Adapter P.19

**Impact Wrenches**  
Optimal performance:  
Up to 32mm  
Adapter P.19

**Magnetic Drills**  
Optimal performance:  
Up to 32mm  
Adapter P.19

**Cordless Drills**  
Possible use  
Up to 16mm

**SDS+ Drills  
(Rotary only mode)**  
Possible use up to 16mm  
Adapter P.20

**Pillar Drills**  
Optimal performance:  
Up to 32mm  
Adapter P.20

**Recommended Power tool**

**Impact Wrench**

Metric	ØD (mm)	Ød1 (mm)	l1 (mm)	L (mm)	Step Diameters (mm)
506010-0160	16	8	77	105	8, 10, 12, 14, 16
506010-0220	22	14	82	110	14, 16, 18, 20, 22
506010-0260	26	18	83	111	18, 20, 22, 24, 26
506010-0320	32	24	87	115	24, 26, 28, 30, 32

Inch	ØD (")	Ød1 (")	l1 (")	L (")	Step Diameters (")
506030-0010	9/16	5/16	3	4-3/16	5/16, 3/8, 7/16, 1/2, 9/16
506030-0020	13/16	9/16	3-1/8	4-5/16	9/16, 5/8, 11/16, 3/4, 13/16
506030-0030	1- 1/16	13/16	3-1/4	4-7/16	13/16, 7/8, 15/16, 1, 1-1/16

## InsertFoam Sets

506010-SET1	16, 22, 26mm
506010-SET2	16, 22, 26, 32mm
506030-SET1	9/16, 13/16, 1-1/16"

Metric Step Depth = 12mm  
Inch Step Depth = 1/2"

"My favourite tool must be the ImpactaStep cutter. Being able to carry just a few TurboTip drill bits & the cutter means most work can be tackled."

**James Sinclair  
Dexta Moors**

InsertFoam Sets are compatible with STAKIT ETOP2 & ETOP4 cases - sold separately - Page 96

**VERSADRIVE®**  
PATENT PROTECTED



VersaDrive® ImpactaTaps are the first and only range of taps that are suitable to be driven by Impact Wrenches and Impact Drivers, providing at least 15x faster performance than tapping by hand.

With a specially designed twin-lead, cutting geometry - the dual hardening process with Titanium coating provides a fantastic solution for tapping holes in steel.

VersaDrive® ImpactaTaps have a patented non-slip, Hex shank suitable for use in any standard 1/2" drill chuck for cordless or Pistol Drills (up to M12) or used with a VersaDrive® Rapid Lock adapter for use in a wide range of powertools such as Magnetic Drills. They can even be used by hand in a socket wrench.



## FEATURES & BENEFITS

- Impact Chipbreaker action for effective swarf evacuation
- Unique twin-point cutting geometry with ground flutes
- Create internal threaded holes with speed and precision
- Quickly clean out and repair damaged or fouled internal threads
- Industrial grade Titanium Nitride coating reduces heat buildup and burn-out
- Use on Impact to prevent dangerous kickback caused by handheld rotary tools
- Heavy-duty hex shank design for secure non-slip operation
- Impact-rated due to dual hardening process - allows up to 15X faster speed than traditional methods

**FOR DETAILED TECHNICAL ADVICE & RPM GUIDANCE SEE P.118**

Watch the video



## POWERTOOL RECOMMENDATIONS ON MILD STEEL



### Impact Drivers

Optimal performance:  
Up to M12  
Possible use up to M16  
Adapter P.19

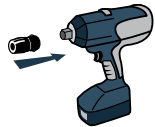

### Impact Wrenches

Optimal performance:  
Up to M30  
Adapter P.19

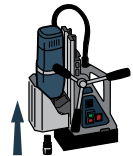

### Reversible Magnetic Drills

Optimal performance:  
Up to M30  
Adapter P.19

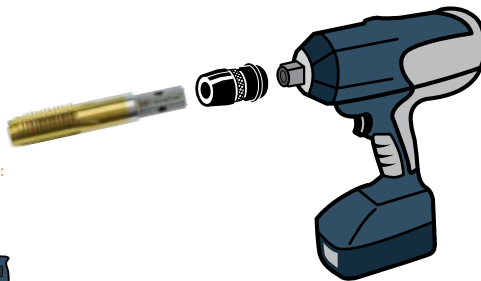

## Recommended Powertool

## Impact Wrench



### Cordless Drills

Optimal performance:  
Up to M8  
Possible use  
Up to M12

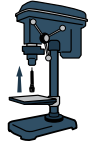

### Pillar Drills

Optimal performance:  
Up to M30  
Adapter P.20

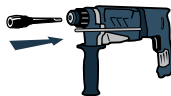

### SDS+ Drills

Not Recommended

Metric Coarse	M Thread Size & Pitch	L (mm)	L1 (mm)	Tap Hole Size (mm)
308010-0050	M5 x 0.80	56	18	4.2
308010-0060	M6 x 1.00	58	20	5
308010-0080	M8 x 1.25	60	22	6.8
308010-0100	M10 x 1.50	70	24	8.5
308010-0120	M12 x 1.75	80	29	10.2
308010-0140	M14 x 2.00	90	32	12
308010-0160	M16 x 2.00	90	32	14
308010-0180	M18 x 2.50	100	37	15.5
308010-0200	M20 x 2.50	100	37	17.5
308010-0240	M24 x 3.00	110	45	21
308010-0270	M27 x 3.00	130	47	24
308010-0300	M30 x 3.50	130	48	26.5

UNC	M Thread Size & Pitch	L (mm)	L1 (mm)	Tap Hole Size
308050-0010	1/4 x 20 UNC	58	20	#7 (5.1mm)
308050-0020	5/16 x 18 UNC	60	22	#F (6.6mm)
308050-0030	3/8 x 16 UNC	70	24	5/16" (8mm)
308050-0040	1/2 x 13 UNC	80	29	27/64" (10.8mm)
308050-0050	5/8 x 11 UNC	90	32	17/32" (13.5mm)
308050-0060	3/4 x 10 UNC	100	37	21/32" (16.5mm)
308050-0065	7/8 x 9 UNC	105	40	49/64" (19.5mm)
308050-0070	1 x 8 UNC	110	45	7/8" (22.25mm)

## InsertFoam Sets

308010-SET1	M6, M8, M10, M12, M16
308010-SET2	M12, M16, M20, M24
308010-SET3	M6, M8, M10, M12, M16, M20, M24
308050-SET1	1/4, 5/16, 3/8, 1/2, 5/8" UNC
308050-SET2	1/2, 5/8, 3/4, 1"UNC

## ImpactaTap & TurboTip Combination Sets

328015-SET1	6.8, 8.5, 10.5 & 14mm TurboTips M8, M10, M12, M16 ImpactaTaps
328016-SET2	#7, #F, 5/16, 27/64" TurboTips 1/4, 5/16, 3/8, 1/2" ImpactaTaps



11mm  
VersaDrive®  
Shank



InsertFoam Sets are compatible with STAKIT ETOP2 & ETOP4 cases - sold separately - Page 96

# VersaDrive® Impact Drill Taps

**VERSADRIVE®**  
PATENT PROTECTED

VersaDrive® Drill Taps are a time saving solution for pilot drilling & tapping in one easy operation. The Titanium coating provides wear resistance and faster cutting performance.

VersaDrive® Sheet Metal Impact-DrillTaps have a patented non-slip, Hex shank suitable for use in any standard 1/2" drill chuck for cordless or Pistol Drills or used with a VersaDrive® Rapid Lock adapter for use in a wide range of powertools such as Magnetic Drills.

Recommended for use with Impact Drivers for high drilling and tapping productivity.



## FEATURES & BENEFITS

- Impact Chipbreaker action for effective swarf evacuation
- Drill pilot holes and then tap in one fast easy operation
- Ground flute twist drill creates the correct pilot hole size
- Rated for material thickness no greater than the diameter of the drill-tap
- Industrial grade Titanium Nitride coating reduces heat buildup and burn-out
- Use on Impact to prevent dangerous kickback caused by handheld rotary tools
- Heavy-duty hex shank design for secure non-slip operation
- Impact-rated due to dual hardening process - allows up to 15X faster speed than traditional methods

**FOR DETAILED TECHNICAL ADVICE & RPM GUIDANCE SEE P.120**

Watch the video



## POWERTOOL RECOMMENDATIONS ON MILD STEEL



**Impact Drivers**

Optimal performance:  
Up to M8  
Possible use up to M12  
Adapter P.19

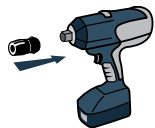

**Impact Wrenches**

Optimal performance:  
M10 & M12  
Possible use up to M18  
Adapter P.19

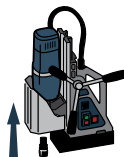

**Reversible Magnetic Drills**

Optimal performance:  
Up to M12  
Adapter P.19

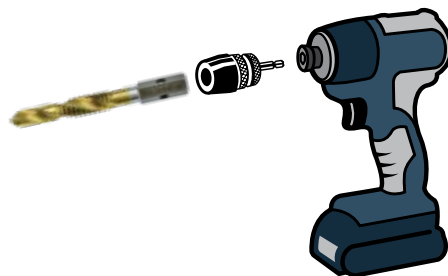

## Recommended Powertool

### Impact Driver



**Cordless Drills**

Optimal performance:  
Up to M6  
Possible use  
Up to M12

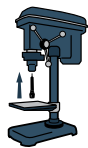

**Pillar Drills**

Optimal performance:  
Up to M12  
Adapter P.20

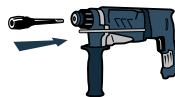

**SDS+ Drills**

Not Recommended

**VERSADRIVE®**  
PATENT PROTECTED

Metric	M Thread Size & Pitch	Max Material Thickness	Ød1 (mm)	L (mm)	l1 (mm)
301125-0030	M3 x 0.50	3mm	2.5	54	4.8
301125-0040	M4 x 0.70	4mm	3.3	68.5	7
301125-0050	M5 x 0.80	5mm	4.2	70	11
301125-0060	M6 x 1.00	6mm	5.0	73.5	13
301125-0080	M8 x 1.25	8mm	6.8	80.5	15
301125-0100	M10 x 1.50	10mm	8.5	89	18
301125-0120	M12 x 1.75	12mm	10.2	102.5	25
Inch	M Thread Size & Pitch	Max Material Thickness	Ød1 (")	L (")	l1 (")
301126-0010	4-40 UNC	3/32	3/32	2-11/64	15/64
301126-0020	6-32 UNC	1/8	7/64	2-23/64	23/64
301126-0030	8-32 UNC	5/32	9/64	2-23/64	23/64
301126-0040	10-24 UNC	13/64	5/32	2-51/64	33/64
301126-0045	12-24 UNC	13/64	5/32	2-51/64	33/64
301126-0050	1/4-20 UNC	1/4	13/64	2-61/64	19/32
301126-0060	5/16-18 UNC	5/16	1/4	3-15/64	45/64
301126-0070	3/8-16 UNC	3/8	5/16	3-5/8	55/64
301126-0080	1/2-13 UNC	1/2	27/64	4/16	1-7/64
InsertFoam Sets					
301125-SET1	M5, M6, M8, M10, M12				
301126-SET1	1/4, 5/16, 3/8, 1/2" UNC				

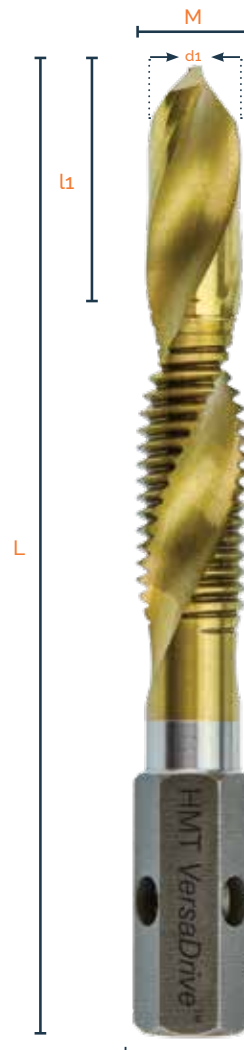

11mm VersaDrive® Shank

"This impact drilltap combo is amazing! No risk of snagging wrists etc and jamming up of the drill when used in the impact gun. Keep it lubed up and the performance is great."

**Tim Berry**  
AnyWeld



InsertFoam Sets are compatible with STAKIT ETOP2 & ETOP4 cases - sold separately - Page 96



# Heavy Duty Drill Taps

**VERSADrive**  
PATENT PROTECTED

VersaDrive® Heavy Duty Drill Taps are an industrial metalwork or fabrication tool for drilling and tapping heavy steel in one easy operation.

Primarily they are designed to be used with a reversible Magnet Drill, although they can also be adapted for use with an Impact Wrench to enlarge and tap existing holes.

With a drill point optimised for use in fixed drilling machines like Magnetic Drills or Pillar drills, these are not recommended for use in a Pistol Drill. Where they are to be used with an Impact Wrench to enlarge and tap holes pilot drilling is recommended with a separate drill bit.



## FEATURES & BENEFITS

- Impact Chipbreaker action for effective swarf evacuation
- Heavy duty straight flute design creates a strong and durable tool
- Ground flute twist drill creates the correct pilot hole size
- Rated for heavy duty plate thicknesses
- Industrial grade Titanium Nitride coating reduces heat buildup and burn-out
- Use on Impact to prevent dangerous kickback caused by handheld rotary tools
- Heavy-duty hex shank design for secure non-slip operation
- Impact-rated due to dual hardening process - allows up to 15X faster speed than traditional methods

**FOR DETAILED TECHNICAL ADVICE & RPM GUIDANCE SEE P.121**

Watch the video



## POWERTOOL RECOMMENDATIONS ON MILD STEEL



**Impact Wrenches**

Possible use  
Up to M24

Adapter P.19

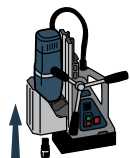

**Reversible  
Magnetic Drills**

Optimal performance:  
Up to M24  
Adapter P.19

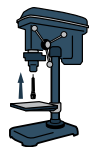

**Pillar Drills**

Optimal performance:  
Up to M24

Adapter P.20

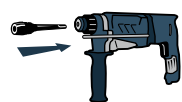

**SDS+ Drills**

Not Recommended



**Impact Drivers**

Not Recommended



**Cordless Drills**

Not Recommended



**Recommended Powertool**

**Magnet Drill**

Metric	M*	Ød1 (mm)	L (mm)	L1 (mm)	MTD** (mm)
301130-0080	M8 x 1.25	6.8	117	28.5	20
301130-0100	M10 x 1.50	8.5	118	27	20
301130-0120	M12 x 1.75	10.2	117	27	25
301130-0160	M16 x 2.00	14	117	25	25
301130-0200	M20 x 2.50	17.5	135	27.5	35
301130-0240	M24 x 3.00	21	150	32	40
Inch	M*	Ød1 (")	L (")	L1 (")	MTD** (")
301140-0001	1/2-13 UNC	27/64	4 -23/32	1-3/8	1
301140-0002	5/8-11 UNC	17/32	5-1/8	1-29/64	1
301140-0003	3/4-10 UNC	21/32	5-33/64	1-37/64	1-3/8
301140-0005	1-8 UNC	7/8	6-19/64	1-49/64	1-37/64
InsertFoam Sets					
301130-SET1	M12, M16, M20, M24				
301130-SET2	M8, M10, M12, M16, M20, M24				
301140-SET1	1/2, 5/8, 3/4, 1"				

\* Thread Size & Pitch

\*\* Max Tapping depth

**VERSADrive**  
PATENT PROTECTED



11mm  
VersaDrive® Shank



"I can certainly recommend the drill taps. These are absolutely amazing, no messing around changing between a drill bit and then tapping. The drill tap will save you no end of time and will last too."

**MSA Fabrication  
Instagram**

InsertFoam Sets are compatible with STAKIT ETOP2 & ETOP4 cases - sold separately - Page 96

The HMT VersaDrive® Clutched tap collet system is a unique method of effectively threading blind holes.

The collet works with the range of Patented VersaDrive® taps. When the tap comes to the bottom of the hole, the clutch system will engage and stop the tap from breaking. The tap is then reversed out of the completed hole.

This system fits a 19.05mm (3/4") Magnet Drill arbor, or can be adapted for use with a 1/2" or 3/4" Impact Wrench.



### FEATURES & BENEFITS

*N.B. Assembled length of Clutched adapter with fitted tap is up to 250mm - ensure you select a mag drill with adequate stroke e.g. V100T & V125T VersaDrive® Magnet Drills*

- Quick change system accepts all VersaDrive® taps
- Collets are pre-set to the appropriate clutch settings
- Further clutch adjustment options available
- For blind hole tapping with VersaDrive® Spiral Flute Taps
- For use with variable speed, reversible, Magnet Drills, pillar drills and Impact Wrenches

Find more info online



Watch the video



Part No	Description
120010	Weldon Shank Tap Collet Holder, 19.05mm / 3/4

121015-M12	Clutched Blind Hole Tap Collet M8-M12 Capacity
121015-M24	Clutched Blind Hole Tap Collet M16-M24 Capacity

00200-12A-19	1/2" Drive Impact Adapter for Blind Hole Tapping
00200-34A-19	3/4" Drive Impact Adapter for Blind Hole Tapping

121015-SET12	Blind Hole Tapping Kit M8-M24 Includes 1/2" Impact Adapter
121015-SET34	Blind Hole Tapping Kit M8-M24 Includes 3/4" Impact Adapter



Metric Coarse	M*	L (mm)	l <sub>1</sub> (mm)	THS**	THS***
309010-0060	M6 x 1.00	58	20	5.0	-
309010-0080	M8 x 1.25	60	22	6.8	-
309010-0100	M10 x 1.50	70	24	8.5	-
309010-0120	M12 x 1.75	80	29	10.2	-
309010-0160	M16 x 2.00	90	32	14.0	-
309010-0200	M20 x 2.50	100	37	17.5	-
309010-0240	M24 x 3.00	110	45	21.0	-
309010-0300	M30 x 3.50	130	48	26.5	-

Inch	M*	L (")	l <sub>1</sub> (")	THS**	THS***
309020-0010	1/4 x 20 UNC	2-3/8	63/64	5.1	#7
309020-0020	5/16 x 18 UNC	2-3/8	63/64	6.6	#F
309020-0030	3/8 x 16 UNC	2-3/4	1	8	5/16
309020-0040	1/2 x 13 UNC	3-1/8	1-3/64	10.8	27/64
309020-0050	5/8 x 11 UNC	3-1/2	1-5/64	13.5	17/32
309020-0060	3/4 x 10 UNC	3-31/32	1-9/64	16.5	21/32
309020-0065	7/8 x 9 UNC	4-1/8	1-13/16	19.5	49/64
309020-0070	1 x 8 UNC	4-3/8	2	22.25	7/8
309020-0110	1-1/4 x 7 UNC	5	2	28	1-7/64

### InsertFoam Sets

309010-SET1	M6, M8, M10, M12, M16
309010-SET2	M12, M16, M20, M24
309020-SET1	1/4, 5/16, 3/8, 1/2, 5/8" UNC
309020-SET2	1/2, 3/4, 1" UNC

\* Thread Size & Pitch \*\* Tap Hole Size (mm) \*\*\* Tap Hole Size (")

### POWERTOOL RECOMMENDATIONS ON MILD STEEL

DETAILED ADVICE & RPM GUIDE - P.119

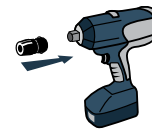

#### Impact Wrenches

Possible use up to M30 with clutched adapter

Adapter P.19

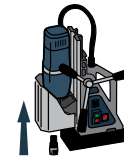

#### Reversible Magnetic Drills

Optimal performance: Up to M30 with clutched adapter Adapter P.19



#### Pillar Drills

Optimal performance: Up to M30 with clutched adapter Adapter P.20



### Recommended Powertool

### Magnet Drill with Clutched Adapter

## ImpactaTaps Long Series - Metric Coarse

**VERSADRIVE**  
PATENT PROTECTED



Part No.	M Thread Size & Pitch	L (mm)	l <sub>1</sub> (mm)	l <sub>2</sub> (mm)	Tap Hole Size (mm)
308015-0080	M8 x 1.25	140	45	112	6.8
308015-0100	M10 x 1.50	155	50	127	8.5
308015-0120	M12 x 1.75	180	55	152	10.2
308015-0160	M16 x 2.0	200	65	172	14
308015-0200	M20 x 2.5	230	70	202	17.5
308015-0240	M24 x 3.0	260	75	232	21

Spiral Point Taps for fast chip ejection in through holes.

## ImpactaTaps Metric Fine Thread

**VERSADRIVE**  
PATENT PROTECTED



Part No.	M Thread Size & Pitch	L (mm)	l <sub>1</sub> (mm)	Tap Hole Size (mm)
308030-0060	M6 x 0.75 MF	60	19	5.2
308030-0800	M8 x 1.00 MF	70	22	7.0
308030-0100	M10 x 1.25 MF	70	24	8.8
308030-0120	M12 x 1.50 MF	80	29	10.5
308030-0160	M16 x 1.50 MF	90	32	14.5
308030-0180	M18 x 1.50 MF	100	37	16.5
308030-0200	M20 x 1.50 MF	100	37	18.5
308030-0240	M24 x 1.50 MF	120	92	22.5

## Metric Coarse Oversized ImpactaTaps

For use with Galvanised Fixings



Part No.	M Thread Size & Pitch	L (mm)	l <sub>1</sub> (mm)	Tap Hole Size (Metric Coarse thread - mm)
308020-0050	M5.4 x 0.80	55	18	4.2
308020-0060	M6.4 x 1.00	55	20	5.0
308020-0080	M8.4 x 1.25	60	22	6.8
308020-0100	M10.4 x 1.50	70	24	8.5
308020-0120	M12.4 x 1.75	80	29	10.2
308020-0160	M16.4 x 2.00	90	32	14.0
308020-0200	M20.4 x 2.50	100	37	17.5
308020-0240	M24.4 x 3.00	110	45	21.0
308020-0300	M30.4 x 3.50	130	48	26.5
<b>Set Contents</b>				
308020-SET1	VersaDrive® Oversize Galv ImpactaTap 6 Pc Set: M5, M6, M8, M10, M12, M16			

## ImpactaTap UNF Thread



Part No.	M Thread Size & Pitch	L (mm)	l <sub>1</sub> (mm)	Tap Hole Size
308051-0010	1/4 x 28 UNF	58	20	#3
308051-0020	5/16 x 24 UNF	60	22	#1
308051-0030	3/8 x 20 UNF	70	24	#Q
308051-0040	1/2 x 20 UNF	80	29	29/64"
308051-0050	5/8 x 18 UNF	90	32	37/64"
308051-0060	3/4 x 16 UNF	100	37	11/16"
308051-0065	7/8 x 14 UNF	105	40	13/16"
308051-0070	1 x 12 UNF	110	45	59/64"



## ImpactaTap BSP Thread

**VERSADRIVE**  
PATENT PROTECTED

## ImpactaTap BSW Thread

**VERSADRIVE**  
PATENT PROTECTED



Part No.	M Thread Size & Pitch	L (mm)	L <sub>1</sub> (mm)	Tap Hole Size (mm)
308070-0010	1/8 x 28 BSP	70	24	8.8
308070-0020	1/4 x 19 BSP	90	32	11.8
308070-0030	3/8 x 19 BSP	90	32	15.25
308070-0040	1/2 x 14 BSP	100	37	19
308070-0050	5/8 x 14 BSP	100	37	21
308070-0060	3/4 x 14 BSP	100	37	24.5
308070-0070	1 x 11 BSP	110	45	30.75



Part No.	M Thread Size & Pitch	L (mm)	L <sub>1</sub> (mm)	Tap Hole Size (mm)
308060-0010	1/4 x 20 BSW	58	20	5.1
308060-0015	5/16 x 18 BSW	60	22	6.5
308060-0020	3/8 x 16 BSW	70	24	7.9
308060-0030	1/2 x 12 BSW	80	29	10.5
308060-0040	5/8 x 11 BSW	90	32	13.5
308060-0050	3/4 x 10 BSW	100	37	16.25
308060-0060	1 x 8 BSW	110	45	22

## ImpactaTap NPT Thread



Part No.	M Thread Size & Pitch	L (mm)	L <sub>1</sub> (mm)	Tap Hole Size
308075-0010	1/8 x 27 NPT	70	19	#R
308075-0020	1/4 x 18 NPT	90	27	7/16"
308075-0030	3/8 x 18 NPT	90	27	37/64"
308075-0040	1/2 x 14 NPT	100	35	23/32"
308075-0050	3/4 x 14 NPT	100	35	59/64"
308075-0060	1 x 11.5 NPT	110	44	1-5/32"

## FarrierTap - BSW Thread



FarrierTap BSW Thread	Part No.	M Thread Size & Pitch	L (mm)	L <sub>1</sub> (mm)	Tap Hole Size (mm)
	308060-0015	5/16 x 18 BSW	60	22	6.5
308060-0020	3/8 x 16 BSW	70	24	7.9	



FarrierTap Combi DrillTap	Part No.	M Thread Size & Pitch	d <sub>1</sub> (mm)	L (mm)	L <sub>1</sub> (mm)	Max tapping depth(mm)
	301127-0030	3/8-16 BSW	7.9	92	22	8.5

FarrierTap Kit	Part No.	Set Contents
	301127-SET1	3/8 BSW FarrierTap, 3/8 BSW Combi Drill Tap, 1/4" VersaDrive <sup>®</sup> Impact Adapter



# VersaDrive® DrillSink Tool

**VERSADRIVE®**  
PATENT PROTECTED

The VersaDrive® DrillSink is an innovative combined drilling & countersinking tool to save metalworkers time & increase hole accuracy by drilling & then countersinking fixing holes in one operation.

This combination tool provides perfect countersinking accuracy every time by locating the drilled hole in perfect alignment to the countersink. This helps prevent tool chatter and blunting commonly found with standard countersinks.

VersaDrive® DrillSinks have a patented non-slip, Hex shank suitable for use in any standard 1/2" drill chuck for Pistol Drills or used with a VersaDrive® Rapid Lock adapter for use in a wide range of powertools such as Magnetic Drills.



## FEATURES & BENEFITS

- Drill & countersink in one easy operation to speed up metalworking
- Ground flutes for high accuracy & long life
- Integrated pilot drill prevents the chattering of standard countersinks
- Perfect concentricity for accurate countersinking
- Industrial grade Titanium Nitride coating reduces heat buildup and burn-out
- Heavy-duty hex shank design for secure non-slip operation
- Quality results on stainless steels and Inox - rotary application recommended
- VersaDrive patented shank and modular adapters provide unbeatable jobsite flexibility

**FOR DETAILED TECHNICAL ADVICE & RPM GUIDANCE SEE P.122**

Watch the video



## POWERTOOL RECOMMENDATIONS ON MILD STEEL

**Impact Drivers**  
Possible use up to 16.5mm countersink size  
Adapter P.19

**Impact Wrenches**  
Possible use up to 16.5mm countersink size  
Adapter P.19

**Magnetic Drills**  
Optimal performance: Up to 25mm countersink size  
Adapter P.19

**Cordless Drills**  
Optimal performance: Up to 25mm countersink size  
Adapter P.20

**SDS+ Drills (Rotary only mode)**  
Possible use up to 25mm countersink size  
Adapter P.20

**Pillar Drills**  
Optimal performance: Up to 25mm countersink size  
Adapter P.20

## Recommended Powertool

**Magnet Drill**

Clearance Hole	Ø D (mm)	Countersink Size (mm)	l1 (mm)	L (mm)	Countersunk Screw	CSK Angle
603070-08124	8	12.4	45	91.2	M6	90°
603070-10165	10	16.5	44.5	84	M8	90°
603070-11205	11	20.5	44	89	M10	90°
603070-12205	12	20.5	44.5	88.5	M10	90°
603070-13250	13	25	44	92	M12	90°
603070-14250	14	25	42	91.7	M12	90°
Tapped Hole	Ø D (mm)	Countersink Size (mm)	l1 (mm)	L (mm)	Countersunk Screw	CSK Angle
603070-68165	6.8	16.5	47	85	M8 (Tap)	90°
603070-85205	8.5	20.5	47	89	M10 (Tap)	90°
603070-102250	10.2	25	47	93	M12 (Tap)	90°
InsertFoam Set						
603070-SET4	8/12.4, 10/16.5, 12/20.5, 14/25mm					



*"Saved so much time with not only having to not switch tooling but also the way in which these tools cut through the metal with such ease. Even after 40+ holes still going strong."*

**Jon Powell**  
J P Fabrications



InsertFoam Sets are compatible with STAKIT ETOP2 & ETOP4 cases - sold separately - Page 96

# VersaDrive® Countersinks

**VERSADRIVE®**  
PATENT PROTECTED

The VersaDrive® Countersink is a premium quality countersink with fully ground flutes and GoldMax Titanium coating to help reduce wear and blunting.

VersaDrive® Countersinks have a patented non-slip, Hex shank suitable for use in any standard 1/2" drill chuck for cordless or Pistol Drills or used with a VersaDrive® Rapid Lock adapter for use in a wide range of powertools such as Magnetic Drills.

Utilise the convenience and power of an Impact Wrench to quickly debur and countersink holes up to 16.5mm with minimal torque kick-back against the operator.



## FEATURES & BENEFITS

- The first impact rated countersink on the market
- Ground flutes for high accuracy & long life
- Perfect concentricity for accurate countersinking
- Industrial grade Titanium Nitride coating reduces heat buildup and burn-out
- Heavy-duty hex shank design for secure non-slip operation
- Quality results on stainless steels and Inox - rotary application recommended
- VersaDrive patented shank and modular adapters provide unbeatable jobsite flexibility

Watch the video



FOR DETAILED TECHNICAL ADVICE & RPM GUIDANCE SEE P.123

## POWERTOOL RECOMMENDATIONS ON MILD STEEL

 <b>Impact Drivers</b> Possible use Up to 16.5mm Adapter P.19	 <b>Impact Wrenches</b> Possible use Up to 16.5mm Adapter P.19	 <b>Magnetic Drills</b> Optimal performance: Up to 31mm Adapter P.19
 <b>Cordless Drills</b> Optimal performance: Up to 20.5mm Possible use Up to 31mm	 <b>SDS+ Drills</b> (Rotary only mode) Possible use Up to 31mm Adapter P.20	 <b>Pillar Drills</b> Optimal performance: Up to 31mm Adapter P.20

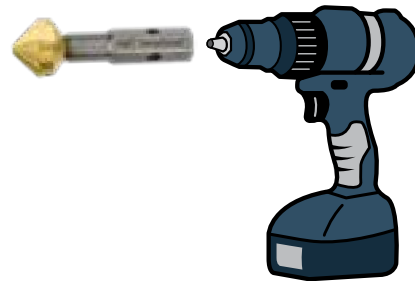

## Recommended Powertool

**Cordless Drill**

Metric - 90°	ØD (mm)	Ød1 (mm)	l1 (mm)	L (mm)	Countersunk Screw	CSK Angle
603060-0063	6.3	1.5	5.5	45	M3	90°
603060-0083	8.3	2.0	6	50	M4	90°
603060-0104	10.4	2.5	8	50	M5	90°
603060-0124	12.4	2.8	8	56	M6	90°
603060-0165	16.5	3.2	11.5	60	M8	90°
603060-0205	20.5	3.5	12	63	M10	90°
603060-0250	25	3.8	15	67.5	M12	90°
603060-0310	31	4.2	18	69	M16	90°
Inch - 82°	ØD (")	Ød1 (")	l1 (")	L (")	Countersunk Screw	CSK Angle
603065-0100	1/4	1/16	7/64	1-27/32	-	82°
603065-0200	3/8	7/64	5/32	2-3/64	-	82°
603065-0300	1/2	7/64	7/32	2-9/32	-	82°
603065-0400	5/8	1/8	9/32	2-7/16	-	82°
603065-0500	3/4	1/8	11/32	2-9/16	-	82°
603065-0600	1	11/64	31/64	2-23/32	-	82°
InsertFoam Sets						
603060-5SET	2.4, 16.5, 20.5, 25, 31mm - 90°					
603065-5SET	3/8, 1/2, 5/8, 3/4, 1" - 82°					



InsertFoam Sets are compatible with STAKIT ETOP2 & ETOP4 cases - sold separately - Page 96



# VERSADRIVE® MAX

The VersaDrive® MAX new product range develops the patented VersaDrive® shank into new territory for the most demanding industrial applications.

The standard VersaDrive® Shank measures 11mm Hex

The new heavy-duty VersaDrive® MAX shank is 20mm Hex meaning it can be used in thicker materials with higher torque application.



## HEAVY DUTY SHANK

This increased shank strength means that VersaDrive® MAX can be used to power larger diameter cutting tools, for example 41mm diameter reamers and M42 Taps.

## PERFECT FOR USE IN:

- Heavy gauge structural steel
- Bridge refurbishment

## VERSADRIVE®

PATENT PROTECTED

(Images below are to scale)



## VERSADRIVE® MAX

DETAILED TECHNICAL ADVICE & RPM GUIDE - P.124



Tested on 50mm thick structural steel with 1" Milwaukee Impact Wrench & MT5 magnetic drilling machines



Impact Wrenches



Magnet Drills

## VersaDrive® MAX Adapters

## HEAVY DUTY

VersaDrive® MAX adapters have been designed to accommodate the larger 20mm VersaDrive® MAX shank & can withstand the highest levels of torque.

Adapters are available to fit VersaDrive® MAX tooling to both Impact Wrenches & high power Magnet Drills.



## FEATURES & BENEFITS

- Use with the highest torque drive tools
- Impact adapters are made to a trusted heavy-duty design with pull forward locking collar
- Impact adapters supplied with retention ring & pin

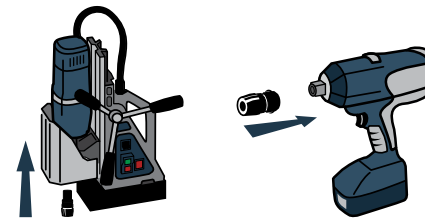

### VersaDrive® MAX HD Impact Wrench Adapter ½" Drive



Part No	ØD (mm)	ØC (mm)	L (mm)
111140-012A	35	30	65

### VersaDrive® MAX HD Magnet Drill Adapter 19.05mm



Part No	ØD (mm)	ØC (mm)	L (mm)
111031-01	34	19.05	63

### VersaDrive® MAX HD Impact Wrench Adapter ¾" Drive



Part No	ØD (mm)	ØC (mm)	L (mm)
111140-034A	35	38	75

### VersaDrive® MAX HD Magnet Drill Adapter 31.75mm



Part No	ØD (mm)	ØC (mm)	L (mm)
111031-02	34	31.75	80

### VersaDrive® MAX HD Impact Wrench Adapter 1" Drive

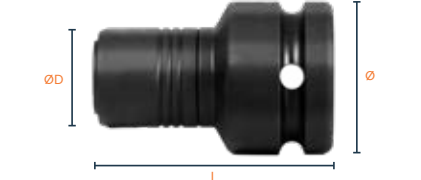

Part No	ØD (mm)	ØC (mm)	L (mm)
111140-100A	35	54	80

# VersaDrive® MAX Reamers

NEW

VERSADRIVE®  
PATENT PROTECTED

VersaDrive® MAX reamers offer a heavy duty solution for enlarging and aligning holes in thick metal plate (e.g. 20mm and above) or at large diameters.

Specially designed cutting geometry and a unique 20mm shank mean they can be used with high torque Impact Wrenches and the most powerful Magnet Drills for superior performance and portability, allowing the job to be completed on-site and not removed for reworking.



## FEATURES & BENEFITS

- Ideal for steel erection & bridge work
- Ideal for modifying & enlarging holes
- Prepare holes for TCB & friction grip bolt
- Use with 1/2", 3/4" & 1" high torque Impact Wrenches
- Use with high torque, low speed Magnetic Drills
- 6 flute design for a faster, smoother cut

Metric	ØD (mm)	Ød1 (mm)	l1 (mm)	l2 (mm)	L (mm)
501050-0180	18	12.2	58	73	181
501050-0220	22	15.4	66	85	201
501050-0230	23	16.4	66	85	201
501050-0240	24	16.8	72	94	216
501050-0260	26	18.8	72	94	216
501050-0280	28	20.2	78	103	231
501050-0300	30	22.2	78	103	231
501050-0320	32	23.6	84	112	246
501050-0330	33	23.6	84	112	246
501050-0350	35	24	92	124	266
501050-0360	36	25	92	124	266
501050-0370	37	26	92	124	266
501050-0380	38	27	92	124	266
501050-0390	39	27	92	124	266
501050-0400	40	28	92	124	266
501050-0410	41	29	92	144	286
Inch	ØD (")	Ød1 (")	l1 (")	l2 (")	L (")
501051-0010	11/16	15/32	2-9/32	2-7/8	7-1/8
501051-0020	13/16	39/64	2-19/32	3-11/32	7-29/32
501051-0030	15/16	21/32	2-27/32	3-45/64	8-1/2
501051-0040	1-1/16	47/64	3-5/64	3-45/64	9-3/32
501051-0050	1-3/16	7/8	3-5/64	4-1/16	9-3/32
501051-0060	1-5/16	63/64	3-5/16	4-13/32	9-11/16
501051-0070	1-3/8	29/32	3-5/8	4-7/8	10-15/32
501051-0080	1-7/16	31/32	3-5/8"	4-7/8	10-15/32
501051-0090	1-1/2	1-1/32	3-5/8	4-7/8	10-15/32
501051-0100	1-9/16	1-3/32	3-5/8	4-7/8	10-15/32
501051-0110	1-5/8	1-5/32	3-5/8	5-43/64	11-1/4
STAKIT Sets					
501050-3SET	18, 22, 26mm + 3/4" Impact Adapter				
501050-4SET	18, 22, 24, 26mm + 3/4" Impact Adapter				
501051-SET1	11/16, 13/16, 15/16" + 3/4" Impact Adapter				
501051-SET2	11/16, 13/16, 15/16, 1-1/16" + 3/4" Impact Adapter				

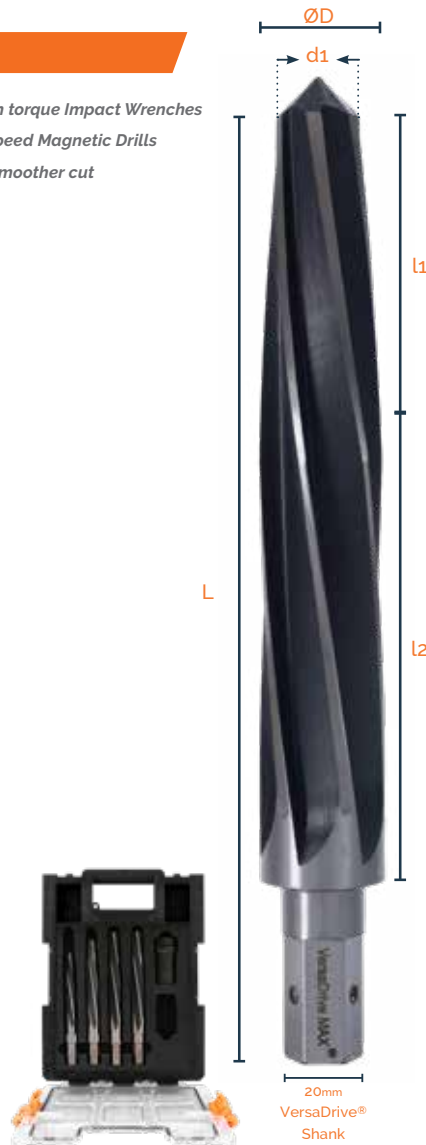

# VersaDrive® MAX Taps

NEW

VERSADRIVE®  
PATENT PROTECTED

VersaDrive® MAX taps are heavy duty, impact rated taps for use in challenging industrial applications.

Based on the bestselling ImpactaTaps, they are double hardened with a unique cutting geometry that makes them suitable for use with impact wrenches.



## FEATURES & BENEFITS

- Thread new holes effectively with high-torque impact wrenches
- Ideal for cleaning and rethreading pre-threaded holes
- Used in commercial vehicle and transportation repair applications
- Can also be used with heavy duty, reversible magnetic drills
- Swarf chipbreaker action for effective use on through holes.

Metric	M Thread Size & Pitch	L (mm)	l2 (mm)
308610-0270	M27 x 3.0	113	45
308610-0300	M30 x 3.5	138	48
308610-0330	M33 x 3.5	151	51
308610-0360	M36 x 4.0	162	57
308610-0390	M39 x 4.0	170	60
308610-0420	M42 x 4.5	170	60
Inch	M Thread Size & Pitch	L (")	l2 (")
308650-0105	1-1/8 x 7 UNC	4-9/16	1-7/8
308650-0110	1-1/4 x 7 UNC	5	2
308650-0120	1-3/8 x 6 UNC	5-3/8	2-1/4
308650-0130	1-1/2 x 6 UNC	5-5/8	2-3/8
308650-0140	1-3/4 x 5 UNC	6-1/4	2-5/8

FURTHER SIZES AVAILABLE ON REQUEST



VersaDrive® TCT HoleCutters are a high performance solution for cutting larger diameter holes quickly and effectively. Premium grade Tungsten Carbide teeth provide ultimate cutting performance in a wide range of metals including Stainless Steel and Cast Iron.

The go-to solution for fabricators and steel erectors needing to drill through heavy steel in locations & on projects where a rotary drill is more convenient & safer than a magnetic drill.

VersaDrive® HoleCutters have a patented non-slip, Hex shank suitable for use in any standard 1/2" drill chuck and can be used with VersaDrive® Rapid Lock adapters for use in a wide range of powertools such as Magnet Drills.

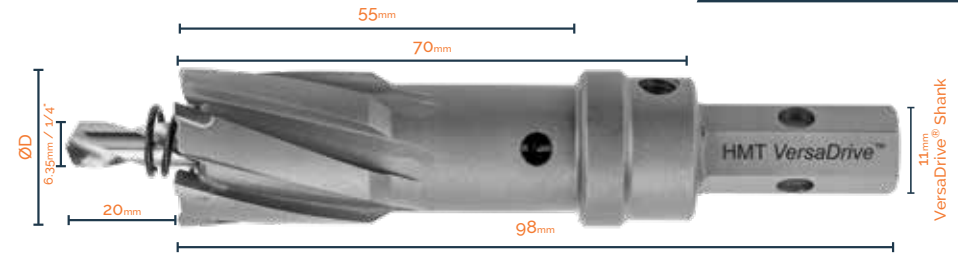

## FEATURES & BENEFITS

- Massive 70mm reach with 55mm depth of cut
- Perfect for drilling heavy steel in remote locations
- Premium quality Tungsten Carbide teeth
- Use with Magnet Drill adapter
- Use in standard 1/2" drill chuck
- One piece design includes arbor & (replaceable) pilot drill
- Combine with MultiSink to broach & countersink in 1 pass

Watch the video



FOR DETAILED TECHNICAL ADVICE & RPM GUIDANCE SEE P.126

## POWERTOOL RECOMMENDATIONS ON MILD STEEL



**Cordless Drills**

Optimal performance:  
Up to 32mm

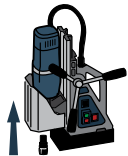

**Magnetic Drills**

Possible use up to  
80mm

Adapter P.19

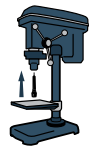

**Pillar Drills**

Optimal performance:  
Up to 80mm

Adapter P.20

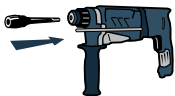
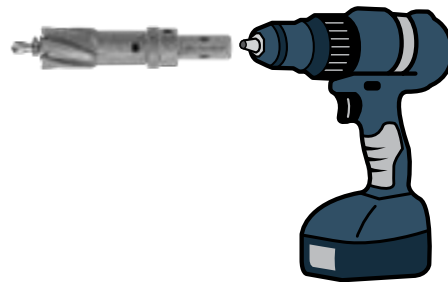

**SDS+ Drills**

(Rotary only mode)  
Possible use up to  
22mm

Adapter P.20

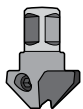

**MultiSink**

Optimal performance:  
from 16-26mm

Adapter P.20

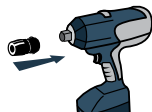

**Impact Tools**

Not Recommended

## Recommended Powertool

**Cordless Drill**

Part No	ØD (mm)	ØD (")	Set Screw
101030-0120	12		M5
101030-0130	13		
101030-0140	14	9/16"	
101030-0150	15		
101030-0160	16	5/8"	
101030-0170	17	11/16"	M6
101030-0175	17.5		
101030-0180	18		
101030-0190	19	3/4"	
101030-0200	20		M8
101030-0210	21	13/16"	
101030-0220	22	7/8"	
101030-0230	23		
101030-0240	24	15/16"	
101030-0250	25	1"	
101030-0260	26		
101030-0270	27	1-1/16"	
101030-0280	28		
101030-0290	29	1-1/8"	
101030-0300	30	1-3/16"	
101030-0310	31		
101030-0320	32	1-1/4"	
101030-0330	33	1-5/16"	
101030-0340	34		

Part No	ØD (mm)	ØD (")	Set Screw
101030-0350	35	1/3-8"	M5
101030-0360	36		
101030-0370	37	1-7/16"	
101030-0380	38	1-1/2"	
101030-0390	39	1-9/16"	
101030-0400	40		
101030-0410	41	1-5/8"	
101030-0420	42		
101030-0430	43	1-11/16"	
101030-0440	44	1-3/4"	
101030-0450	45		M8
101030-0460	46	1-13/16"	
101030-0470	47		
101030-0480	48	1-7/8"	
101030-0490	49		
101030-0500	50		
101030-0510	51	2"	
101030-0520	52	2-1/16"	
101030-0550	55	2-5/32"	
101030-0600	60	2-3/8"	
101030-0650	65	2-9/16"	
101030-0700	70	2-3/4"	
101030-0750	75		
101030-0800	80	3-5/32"	

101030P-0001



101030P-0003



### Pilot Pins

101030P-0130	Pilot Drill for 12 & 13mm HoleCutters (2pk) (Supplied WITHOUT ejection spring)
101030P-0001	Pilot Drill for 14-80mm HoleCutters (2pk) (Supplied WITH ejection spring)
101030P-0003	VersaDrive® HoleCutter Magnet Broaching/MultiSink Pilot Pin, (2pk)

101030P-0004



### HoleCutter Upgrade Kit

101030P-0004	VersaDrive® TCT HoleCutter Upgrade Kit 1 x TurboTip 1/4" / 6.35mm & 1 x Pilot Pin
--------------	--

TurboTip pilot drill upgrade for added performance on thick materials  
Solid steel pilot pin prevents snagging & snapping while drilling thick materials

HoleCutter InsertFoam Sets - P59



# VersaDrive® Extra Long HoleCutters

**VERSADRIVE®**  
PATENT PROTECTED

Extra Long reach version of the popular VersaDrive® HoleCutter. Perfect for small diameter drilling through steelwork using a Pistol Drill where a separate extension isn't practical.

Ideal for applications where a metal plate is encountered amongst wood joists or where both sides of a steel beam require drilling.

These are rapidly becoming the go-to solution for fabricators and steel erectors needing to drill through heavy steel in locations and on projects where a rotary drill is more convenient & safer than a magnetic drill.



## FEATURES & BENEFITS

- Massive 120mm reach with 100mm depth of cut
- Perfect for drilling heavy steel in remote locations
- Perfect for drilling box section with inaccessible sides
- Premium quality Tungsten Carbide teeth
- Use with Magnet Drill adapter
- Use in standard 1/2" drill chuck
- One piece design includes arbor & (replaceable) pilot drill
- Combine with MultiSink to broach & countersink in 1 pass

Watch the video



FOR DETAILED TECHNICAL ADVICE & RPM GUIDANCE SEE P.126

## POWERTOOL RECOMMENDATIONS ON MILD STEEL



**Cordless Drills**

Optimal performance:  
Up to 26mm

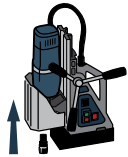

**Magnetic Drills**

Possible use up to  
26mm

Adapter P.19

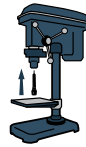

**Pillar Drills**

Optimal performance:  
Up to 26mm

Adapter P.20

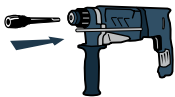
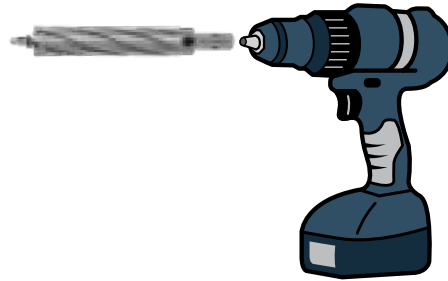

**SDS+ Drills**  
(Rotary only mode)

Possible use up to  
22mm

Adapter P.20

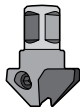

**MultiSink**

Optimal performance:  
from 16-26mm

Adapter P.20



**Impact Tools**

Not Recommended

## Recommended Powertool

**Cordless Drill**

Part No	ØD (mm)	ØD (")	Set Screw
101035-0140	14	9/16"	M5
101035-0170	17	11/16"	M6
101035-0180	18		
101035-0200	20		
101035-0210	21	13/16"	M8
101035-0220	22	7/8"	
101035-0240	24	15/16"	
101035-0260	26		



## Pilot Drill Bits & Pins

101035P-01	Extra Long TCT HoleCutter Pilot Drills 6.35x165mm, (2pk)
101035P-02	Extra Long HoleCutter Guide Pin 6.35x205mm, (2pk)

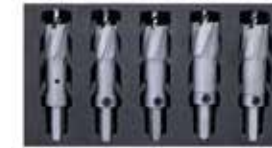

## 101030 HoleCutter Sets - 55mm Cutting Depth

101030-SET1	14, 18, 22mm
101030-SET2	14, 17, 18, 21, 22mm
101030-INSET1	9/16, 11/16, 13/16"
101030-INSET2	9/16, 11/16, 13/16, 15/16, 1-1/16"



## 101035 HoleCutter Set - 100mm Cutting Depth

101035-SET1	14, 18, 20, 24, 26mm
-------------	----------------------

**VERSADRIVE®**  
PATENT PROTECTED

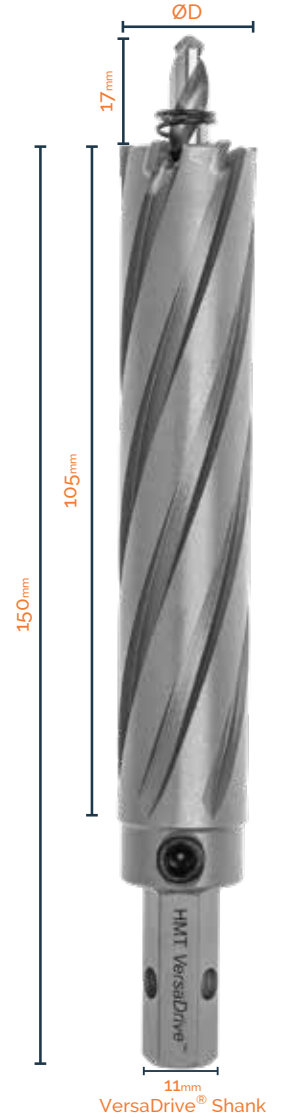

"We don't need the magdrill on site any more. So versatile, so easy, massive time saver."

**Duncan Platford**  
LinkedIn

InsertFoam Sets are compatible with STAKIT ETOP2 & ETOP4 cases - sold separately - Page 96

## CarbideMax 40 Broach Cutter

## WELDON SHANK

The CarbideMax® 40 Series will broach up to 35mm thickness of metal. Individually brazed cutting teeth are made from Tungsten Carbide capable of drilling through the toughest steels.

- Up to 10x longer life than traditional HSS Cutters
- 64% Faster cuts than HSS cutters
- Advanced triple-cut geometry for faster, quieter drilling
- Chatter free performance

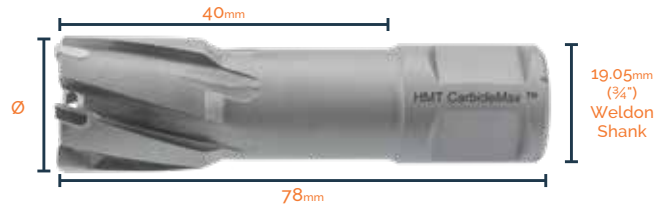

Part No	D Ø (mm)
108030-0120	12
108030-0130	13
108030-0140	14
108030-0150	15
108030-0160	16
108030-0170	17
108030-0180	18
108030-0190	19
108030-0200	20
108030-0210	21
108030-0220	22
108030-0230	23
108030-0240	24
108030-0250	25
108030-0260	26
108030-0270	27
108030-0280	28
108030-0290	29
108030-0300	30
108030-0310	31
108030-0320	32
108030-0330	33
108030-0340	34

Part No	D Ø (mm)
108030-0350	35
108030-0360	36
108030-0370	37
108030-0380	38
108030-0390	39
108030-0400	40
108030-0410	41
108030-0420	42
108030-0430	43
108030-0440	44
108030-0450	45
108030-0460	46
108030-0470	47
108030-0480	48
108030-0490	49
108030-0500	50
108030-0550	55
108030-0600	60
108030-0650	65
108030-0700	70
108030-0750	75
108030-0800	80

## CarbideMax 55 Broach Cutter

## WELDON SHANK

The CarbideMax® 55 Series will broach up to 50mm thickness of metal. Individually brazed cutting teeth are made from Tungsten Carbide capable of drilling through the toughest steels.

- Up to 10x longer life than traditional HSS Cutters
- 64% Faster cuts than HSS cutters
- Advanced triple-cut geometry for faster, quieter drilling
- Chatter free performance

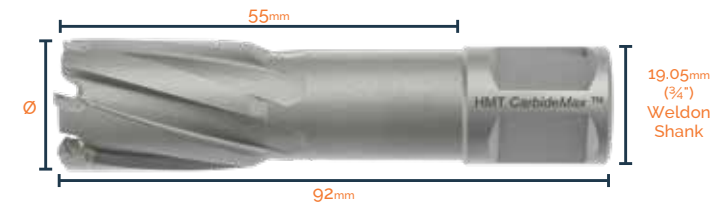

Part No	D Ø (mm)
108020-0120	12
108020-0130	13
108020-0140	14
108020-0150	15
108020-0160	16
108020-0170	17
108020-0175	17.5
108020-0180	18
108020-0190	19
108020-0200	20
108020-0210	21
108020-0220	22
108020-0230	23
108020-0240	24
108020-0250	25
108020-0260	26
108020-0265	26.5
108020-0270	27
108020-0280	28
108020-0290	29
108020-0300	30
108020-0310	31
108020-0320	32
108020-0330	33
108020-0340	34

Part No	D Ø (mm)
108020-0350	35
108020-0360	36
108020-0370	37
108020-0380	38
108020-0390	39
108020-0400	40
108020-0410	41
108020-0420	42
108020-0430	43
108020-0440	44
108020-0450	45
108020-0460	46
108020-0470	47
108020-0480	48
108020-0490	49
108020-0500	50
108020-0510	51
108020-0520	52
108020-0530	53
108020-0540	54
108020-0550	55
108020-0560	56
108020-0570	57
108020-0580	58
108020-0590	59
108020-0600	60



Pilot Pins			
For 12-17mm cutters	ØD	Length	Unit of sale
108030P-0170	6.34mm	90mm	Pack 2
108030P-0170-P10	6.34mm	90mm	Pack 10
For 18-80mm cutters	ØD	Length	Unit of sale
108030P-0600	7.98mm	90mm	Pack 2
108030P-0600-P10	7.98mm	90mm	Pack 10

InsertFoam Sets	
108030-SET	14, 18, 22mm + 2 Pilot Pins
108030-5SET	12, 14, 18, 22, 26mm + 2 Pilot Pins

Pilot Pins			
For 12-17mm cutters	ØD	Length	Unit of sale
108020P-0170	6.34mm	106mm	Pack 2
108020P-0170-P10	6.34mm	106mm	Pack 10
For 17.5-60mm cutters	ØD	Length	Unit of sale
108020P-0600	7.98mm	106mm	Pack 2
108020P-0600-P10	7.98mm	106mm	Pack 10

InsertFoam Sets	
108020-SET	14, 18, 22mm + 2 Pilot Pins
108020-5SET	12, 14, 18, 22, 26mm + 2 Pilot Pins

## CarbideMax 80 Broach Cutter

## WELDON SHANK

The CarbideMax® 80 Series will broach up to 75mm thickness of metal. Individually brazed cutting teeth are made from Tungsten Carbide capable of drilling through the toughest steels.

- Up to 10x longer life than traditional HSS Cutters
- 64% Faster cuts than HSS cutters
- Advanced triple-cut geometry for faster, quieter drilling
- Chatter free performance

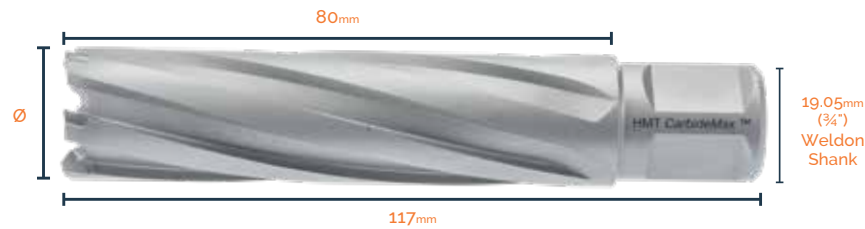

Part No	D Ø (mm)
108010-0120	12
108010-0140	14
108010-0160	16
108010-0180	18
108010-0200	20
108010-0220	22
108010-0240	24
108010-0260	26
108010-0280	28
108010-0300	30
108010-0320	32

Part No	D Ø (mm)
108010-0330	33
108010-0340	34
108010-0350	35
108010-0360	36
108010-0380	38
108010-0390	39
108010-0400	40
108010-0420	42
108010-0450	45
108010-0500	50



Pilot Pins			
For 12-17mm cutters	ØD	Length	Unit of sale
108010P-0170	6.34mm	130mm	Pack 2
For 18-60mm cutters			
108010P-0600	7.98mm	130mm	Pack 2

InsertFoam Sets	
108010-SET	18, 22, 24, 26, 28, 30mm + 2 Pilots

## CarbideMax 110 Broach Cutter

## WELDON SHANK

The CarbideMax® 110 Series will broach up to 105mm thickness of metal. Individually brazed cutting teeth are made from Tungsten Carbide capable of drilling through the toughest steels.

- Up to 10x longer life than traditional HSS Cutters
- 64% Faster cuts than HSS cutters
- Advanced triple-cut geometry for faster, quieter drilling
- Chatter free performance

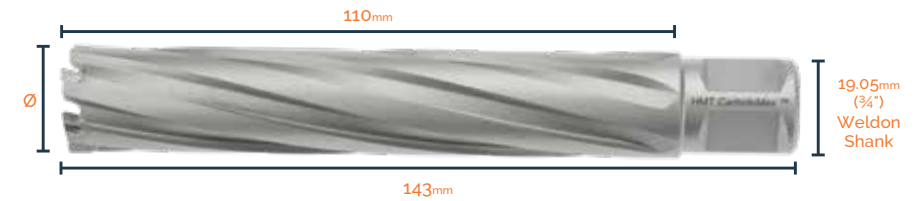

Part No	D Ø (mm)
108040-0140	14
108040-0160	16
108040-0180	18
108040-0190	19
108040-0200	20
108040-0210	21
108040-0220	22
108040-0230	23
108040-0240	24
108040-0250	25
108040-0260	26
108040-0270	27
108040-0280	28
108040-0290	29
108040-0300	30
108040-0320	32
108040-0330	33
108040-0340	34
108040-0350	35
108040-0360	36
108040-0380	38

Part No	D Ø (mm)
108040-0390	39
108040-0400	40
108040-0410	41
108040-0420	42
108040-0430	43
108040-0440	44
108040-0450	45
108040-0460	46
108040-0470	47
108040-0480	48
108040-0490	49
108040-0500	50
108040-0510	51
108040-0520	52
108040-0540	54
108040-0550	55
108040-0560	56
108040-0570	57
108040-0580	58
108040-0590	59
108040-0600	60

Pilot Pins			
For 14-17mm cutters	ØD	Length	Unit of sale
108040P-0171	6.34mm	155mm	Pack 2
For 18-60mm cutters			
108040P-0600	7.98mm	155mm	Pack 2

InsertFoam Sets	
108040-SET	14, 18, 22, 24, 26mm + 2 Pilots



## CarbideMax 150 Broach Cutter

## WELDON SHANK

Extreme drilling depth with CarbideMax® Extra Long.

For the most extreme drilling depths the CarbideMax® range offers 150mm extra long broach cutters.

With precision drilling flutes and a specially engineered geometry for accurate cutting these cutters come with a standard 19.05mm Weldon shank for use in any Magnet Drill with sufficient stroke.

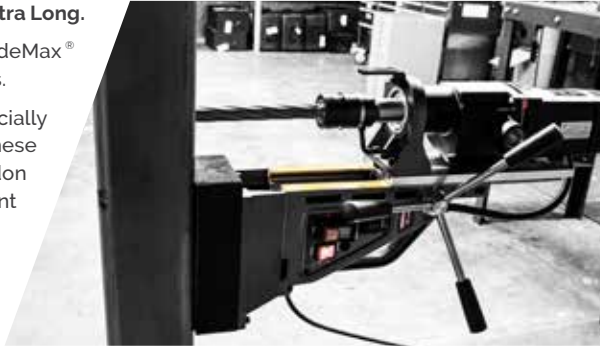

Drill matching holes through box or H section in a single pass

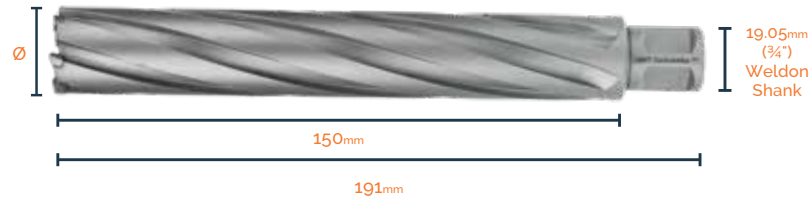

Part No.	D Ø (mm)
108045-0180	18
108045-0200	20
108045-0220	22
108045-0240	24
108045-0260	26
108045-0280	28
108045-0300	30
108045-0320	32
108045-0330	33
108045-0360	36
108045-0390	39
108045-0500	50



Pilot Pins			
Part No.	D Ø	Length	Unit of sale
108045P-0600	7.98mm	205mm	Pack 2

## CarbideMax 200 Broach Cutter

## WELDON SHANK

Extreme drilling depth with CarbideMax® Extra Long.

For the most extreme drilling depths the CarbideMax® range offers 200mm extra long broach cutters.

With precision drilling flutes and a specially engineered geometry for accurate cutting these cutters come with a standard 19.05mm Weldon shank for use in any Magnet Drill with sufficient stroke.



Drill matching holes through box or H section in a single pass

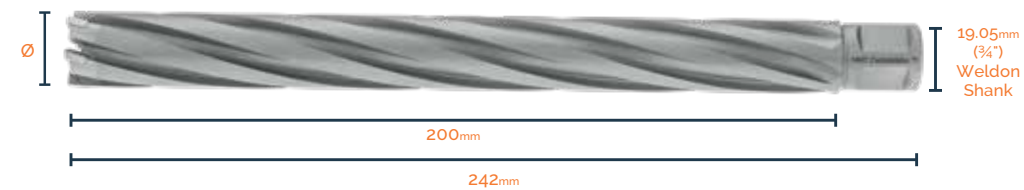

Part No.	D Ø (mm)
108050-0180	18
108050-0200	20
108050-0220	22
108050-0240	24
108050-0260	26
108050-0300	30
108050-0320	32
108050-0330	33
108050-0360	36
108050-0390	39
108050-0420	42
108050-0450	45
108050-0500	50



Pilot Pins			
Part No.	D Ø	Length	Unit of sale
108050P-0600-2P	7.98mm	255mm	Pack 2

When using the 2 part pilot pin and drilling material greater than 50mm thick, when the pilot pin reaches the extent to which it can retract inside the Magnet Drill arbor, the bottom section of the pilot can be removed to allow the hole to be completed without removing the pilot pin from the cutter.

## CarbideMax XL55 Broach Cutters

31.75<sub>mm</sub> WELDON SHANK

### Ultra large diameter drilling with CarbideMax® XL.

With the requirement for ultra large diameter broaching fast increasing, the CarbideMax-XL® range offers cutters from 61mm up to 150mm diameter with a 55mm cutting depth.

These high quality TCT cutters have a reinforced 31.75mm diameter shank to withstand the high levels of torque generated.

Adapters are available to convert the 31.75mm shank for use with standard 19.05mm weldon shank Magnet Drills.



Part No.	D Ø (mm)
108020-0610	61
108020-0620	62
108020-0630	63
108020-0640	64
108020-0650	65
108020-0660	66
108020-0670	67
108020-0680	68
108020-0690	69
108020-0700	70
108020-0750	75
108020-0800	80
108020-0850	85
108020-0900	90

Part No.	D Ø (mm)
108020-0950	95
108020-1000	100
108020-1050	105
108020-1100	110
108020-1150	115
108020-1200	120
108020-1250	125
108020-1270	127
108020-1300	130
108020-1350	135
108020-1400	140
108020-1450	145
108020-1500	150

### 31.75mm to 19.05mm Weldon Shank Adapter & Pilot



Adapts 31.75mm shank cutters to 19.05mm standard Magnet Drill fitting; includes pilot

Part No	Details
103091-1932-55	19.05 Male to 31.75mm Female Weldon Adapter + Pilot for 55mm cutters

### 31.75mm Weldon Shank Morse Taper Arbor & Pilot



Spring loaded for cutter slug ejection

Part No	Arbor Size	Shank Size
103013-0323	MT3	31.75mm / 1 1/4"
103013-0324	MT4	31.75mm / 1 1/4"
108020P-1500	CarbideMax55 Pilot Pin, 61-150mm, Pk 2	

## CarbideMax XL110 Broach Cutters

31.75<sub>mm</sub> WELDON SHANK

### Ultra large diameter drilling with CarbideMax® XL.

With the requirement for ultra large diameter broaching fast increasing, the CarbideMax-XL® range offers cutters from 61mm up to 200mm diameter with a 110mm cutting depth.

These high quality TCT cutters have a reinforced 31.75mm diameter shank to withstand the high levels of torque generated.

Adapters are available to convert the 31.75mm shank for use with standard 19.05mm weldon shank Magnet Drills.



Part No.	ØD (mm)
108040-0610	61
108040-0620	62
108040-0630	63
108040-0640	64
108040-0650	65
108040-0660	66
108040-0670	67
108040-0680	68
108040-0690	69
108040-0700	70
108040-0730	73
108040-0750	75
108040-0800	80
108040-0850	85
108040-0900	90
108040-0950	95

Part No.	ØD (mm)
108040-1000	100
108040-1050	105
108040-1100	110
108040-1150	115
108040-1200	120
108040-1250	125
108040-1300	130
108040-1350	135
108040-1400	140
108040-1500	150
108040-1600	160
108040-1700	170
108040-1800	180
108040-1900	190
108040-2000	200

### 31.75mm to 19.05mm Weldon Shank Adapter & Pilot



Adapts 31.75mm shank cutters to 19.05mm standard Magnet Drill fitting; includes pilot

Part No	Details
103091-1932-110	19.05 Male to 31.75mm Female Weldon Adapter + Pilot for 110mm cutters

### 31.75mm Weldon Shank Morse Taper Arbor & Pilot



Spring loaded for cutter slug ejection

Part No	Arbor Size	Shank Size
103013-0323	MT3	31.75mm / 1 1/4"
103013-0324	MT4	31.75mm / 1 1/4"
108040P-1500-2P	CarbideMax110 2 Piece Pilot Pin 61-200mm, Pk2	



The NEW VersaDrive® **STAKIT** Hardox Kit has been developed to offer a comprehensive solution to drilling & countersinking the most challenging materials.

With cutting tools from 6 - 26mm diameter and countersinking options up to 40mm, this kit is a must have for operatives in the quarrying/mining, heavy machinery/plant repair and defence sectors.

**Metric Kit Contents:**

- 5 x CarbideMax ULTRA 55 TCT Broach Cutters 18, 20, 22, 24, 26mm **Now includes VersaDrive® 111030-0002 Weldon Magnet Drill Adapter**
- 5 x VersaDrive® ULTRA Drill Bits 6, 8, 10, 12, 14mm
- 1 x Weldon Shank ULTRA TCT Countersink 32mm, 90°
- 1 x ULTRA coated Tungsten Carbide MultiSink 40mm, 90°
- 5 x MultiSink Pilots 18, 20, 22, 24, 26mm
- 1 x VersaDrive® Heavy Duty Magnet Drill Adapter
- 1 x VersaDrive® **STAKIT** ETOP4 Full Top Case



**L x W x H (mm) - 540 x 390 x 95**

**See website for Inch Kit & Contents**

Part No	Product
<b>STC-HARDOX-KIT</b>	<b>STAKIT</b> Ultra Hardox Kit - Metric Sizes

**ULTRA Weldon Countersink**

Premium, ULTRA coated countersink with 3X heavy duty tungsten carbide inserts for maximum life in challenging materials. Standard 19.05mm Weldon shank for use in all standard Magnet Drills. Use with a 103013 Morse taper arbor to use in a Pillar Drill or Radial Drill. For use on materials like Hardox & other wear plate.

Part No	Size
<b>601036-0320</b>	32mm ULTRA Countersink 90°
<b>601038-0010</b>	1-1/4" ULTRA Countersink 82°

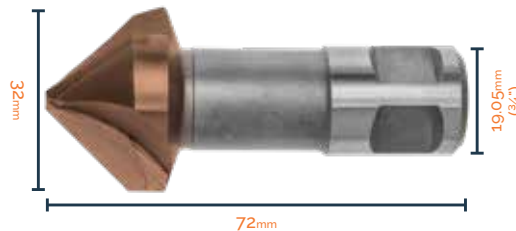

The Ultra coated MultiSink and Weldon Countersink offer increased wear resistance and long-life performance whilst countersinking the most challenging applications, including materials like Hardox, Inconel and Armor plate.

The MultiSink is a worldwide unique new Combination Countersink Tool designed & developed by HMT for use with Magnetic Drills.



**FEATURES & BENEFITS**

**FOR DETAILED TECHNICAL ADVICE & RPM GUIDANCE SEE P.128**

- Innovative combination countersinking tool
- Suitable for holes 16mm and above
- Save time completing countersunk holes
- Pilot feature gives a precise, concentric fit for excellent performance

Part No	D Ø	D2	L	Shank	Point Angle
<b>601056-0400</b>	40mm	14mm	100mm	19.05mm / 3/4"	90°
<b>601056-0550</b>	55mm	14mm	109mm	19.05mm / 3/4"	90°
<b>601058-0010</b>	1-1/2"	9/16"	3-15/16"	3/4" / 19.05mm	82°
<b>601058-0020</b>	2-1/4"	9/16"	4-5/16"	3/4" / 19.05mm	82°

**MultiSink Pilots**

Part No	D Ø	Length	Shank
<b>601050-0160</b>	16mm	52mm	11mm
<b>601050-0180</b>	18mm		
<b>601050-0200</b>	20mm		
<b>601050-0220</b>	22mm		
<b>601050-0240</b>	24mm		
<b>601050-0260</b>	26mm	2-3/64"	7/16"
<b>601051-0010</b>	9/16"		
<b>601051-0015</b>	5/8"		
<b>601051-0020</b>	11/16"		
<b>601051-0025</b>	3/4"		
<b>601051-0030</b>	13/16"		
<b>601051-0035</b>	7/8"		
<b>601051-0040</b>	15/16"		



Use MultiSink pilot when countersinking bolt holes from 16 - 26mm diameter. Use MultiSink with variable speed Magnet Drill. The speed must be reduced when countersinking.



# CarbideMax ULTRA55

# WELDON SHANK

CarbideMax® Ultra cutters are specifically designed for long-life performance in the toughest broaching jobs on the planet, including Hardox steel.

- Individually brazed, highest quality carbide cutting teeth
- ULTRA coated for optimum performance & lifespan
- Advanced triple-cut geometry for faster, quieter drilling
- Chatter free performance when used correctly



Part No.	ØD (mm)
108070-0160	16
108070-0170	17
108070-0175	17.5
108070-0180	18
108070-0190	19
108070-0200	20
108070-0210	21
108070-0220	22
108070-0230	23
108070-0240	24
108070-0250	25
108070-0260	26
108070-0265	26.5
108070-0270	27
108070-0280	28
108070-0290	29
108070-0300	30
108070-0310	31
108070-0320	32
108070-0330	33
108070-0340	34
108070-0350	35
108070-0360	36
108070-0370	37

### Pilot Pins

For 12-17mm cutters	ØD	Length	Unit of sale
108020P-0170	6.34mm	103mm	Pack 2
For 18-60mm cutters	ØD	Length	Unit of sale
108020P-0600	7.98mm	103mm	Pack 2

Part No.	ØD (mm)
108070-0380	38
108070-0390	39
108070-0400	40
108070-0410	41
108070-0420	42
108070-0430	43
108070-0440	44
108070-0450	45
108070-0460	46
108070-0470	47
108070-0480	48
108070-0490	49
108070-0500	50
108070-0510	51
108070-0520	52
108070-0530	53
108070-0540	54
108070-0550	55
108070-0560	56
108070-0570	57
108070-0580	58
108070-0590	59
108070-0600	60

### InsertFoam Sets

108070-SET2	18, 20, 22, 24, 26mm + 2 Pilots
-------------	---------------------------------



# CarbideMax ULTRA110

# WELDON SHANK

CarbideMax® Ultra cutters are specifically designed for long-life performance in the toughest broaching jobs on the planet, including Hardox steel.

- Individually brazed, highest quality carbide cutting teeth
- ULTRA coated for optimum performance & lifespan
- Advanced triple-cut geometry for faster, quieter drilling
- Chatter free performance when used correctly



Part No.	ØD (mm)
108090-0160	16
108090-0180	18
108090-0190	19
108090-0200	20
108090-0210	21
108090-0220	22
108090-0230	23
108090-0240	24
108090-0250	25
108090-0260	26
108090-0270	27
108090-0280	28
108090-0290	29
108090-0300	30
108090-0320	32
108090-0330	33
108090-0340	34
108090-0350	35
108090-0360	36
108090-0380	38
108090-0390	39

Part No.	ØD (mm)
108090-0400	40
108090-0410	41
108090-0420	42
108090-0430	43
108090-0440	44
108090-0450	45
108090-0460	46
108090-0470	47
108090-0480	48
108090-0490	49
108090-0500	50
108090-0510	51
108090-0520	52
108090-0540	54
108090-0550	55
108090-0560	56
108090-0570	57
108090-0580	58
108090-0590	59
108090-0600	60

### Pilot Pins

For 14-17mm cutters	ØD	Length	Unit of sale
108040P-0171	6.34mm	155mm	Pack 2
For 18-60mm cutters	ØD	Length	Unit of sale
108040P-0600	7.98mm	155mm	Pack 2

# ULTRA Coated Twist Drill Bits

NEW

**VERSADrive**  
PATENT PROTECTED

VersaDrive® Ultra Drill Bits - for Hardox, Wear Plate, Armour Plate and RailTrack signalling/bonding applications.

The new VersaDrive® Ultra Drill bits are designed for the toughest applications in the mining, quarrying, and military engineering market. VersaDrive Ultra Drill bits are also suitable for use drilling holes for bonding wires in track circuit signalling / bonding and wheel detector applications.

High grade tool steel combined with the specialist high-performance Ultra coating provides the ability to drill the toughest materials.

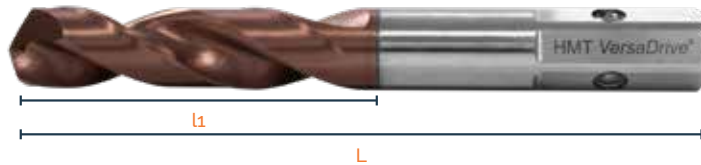

Metric	ØD (mm)	l1 (mm)	L (mm)
209020-0040	4	22	55
209020-0050	5	26	62
209020-0060	6	28	66
209020-0070	7	34	74
209020-0080	8	37	79
209020-0090	9	40	84
209020-0100	10	43	89
209020-0110	11	47	95
209020-0120	12	51	102
209020-0130	13	51	102
209020-0140	14	54	107
Inch	ØD (")	l1 (")	L (")
209021-0010	1/4	1-3/8	2-1/2
209020-0070	9/32	1-11/32	2-15/16
209021-0020	5/16	1-5/8	2-13/16
209021-0030	3/8	1-13/16	3-1/8
209021-0040	1/2	2-1/4	3-3/4
209021-0050	9/16	2-43/64	4-11/16

## InsertFoam Sets

209020-SET1	6, 8, 10, 12, 14mm
209020-SET2	4, 5, 6, 7, 8, 9, 10, 11, 12, 13, 14mm
209021-SET1	1/4, 5/16, 3/8, 1/2, 9/16"



FOR DETAILED TECHNICAL ADVICE & RPM GUIDANCE SEE P.128

# ULTRA Straight-Flute Cutters

# WELDON SHANK

Specially designed flute profile and cutting geometry ensures that HMT Straight-Flute cutters offer superior performance in hard materials like Rail Track, Hardox, Armour plate and Stainless Steel.

Suitable for use with Cembre, Rotabroach and other similar rail track drilling machines as well as all standard 19.05mm magnet drills.



30mm Cutting Depth	D Ø (mm)
106030-0180	18
106030-0200	20
106030-0220	22
106030-0240	24
106030-0260	26
106030-0280	28
106030-0300	30
106030-0320	32
106030-0330	33
106030-0360	36

55mm Cutting Depth	D Ø (mm)
106020-0180	18
106020-0200	20
106020-0220	22
106020-0240	24
106020-0260	26
106020-0280	28
106020-0300	30
106020-0320	32
106020-0330	33
106020-0360	36

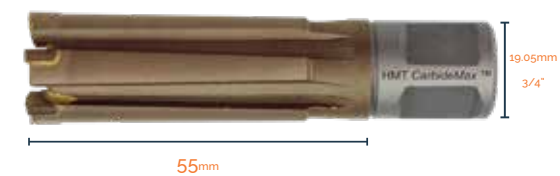

30mm Cutting Depth	D Ø (mm)
106035-0180	18
106035-0200	20
106035-0220	22
106035-0240	24
106035-0260	26
106035-0280	28
106035-0300	30
106035-0320	32
106035-0330	33
106035-0360	36

55mm Cutting Depth	D Ø (mm)
106025-0180	18
106025-0200	20
106025-0220	22
106025-0240	24
106025-0260	26
106025-0280	28
106025-0300	30
106025-0320	32
106025-0330	33
106025-0360	36

## Pilot Pins

For 30mm Cutting Depth	ØD	Length	Unit of sale
106030P-0360	7.98mm	77mm	Pack 2
For 55mm Cutting Depth	ØD	Length	Unit of sale
108020P-0600	7.98mm	103mm	Pack 2



## HMT V35 Magnet Drill

HOLEMAKER TECHNOLOGY  
**HMT**

The HMT V35 is the first UK Built portable drilling machine designed for high-performance, low-maintenance, industrial quality drilling up to 35mm diameter.

With a 140mm stroke, maximum cutter length of 110mm and seamless integration with the VersaDrive® modular cutting system, it offers the most flexibility of any compact Magnet Drill on the market.



### FEATURES & BENEFITS

- 140mm Stroke
- 110mm Cutting Depth
- Only 9.5kg

### TECHNICAL SPECIFICATIONS

CUTTER SIZE RANGE	12 - 35mm TCT
MAX CUTTER CAPACITY	35mm
MAX CUTTER LENGTH	110mm
TWIST DRILL CAPACITY	12mm
COUNTERSINKING	25mm
REAMING	N/A
MAX TAP CAPACITY	N/A
LENGTH	220mm
WIDTH (Inc Handles)	173mm
HEIGHT (Min-Max)	305 - 445mm
STROKE	140mm
WEIGHT	9.5kg
MAGNET (L X W)	160 x 80mm
MAGNETIC ADHESION	1000kg
MOTOR POWER	850W
TOTAL POWER	900W
SPEED RPM (No Load)	750
SPINDLE	3/4" Weldon
ARBOR	Integral 3/4" Weldon
COOLANT SYSTEM	Gravity Oil Fed
WARRANTY	2 Year (When registered)



Part No	Contents
850035-110	V35 Magnetic Drill Kit 110v
850035-230	V35 Magnetic Drill Kit 230v



Supplied in **STAKIT Base 200** case, with **Rapid-Lock VersaDrive®** adapter

## HMT V36 (18Volt) Cordless Magnet Drill

HOLEMAKER TECHNOLOGY  
**HMT**

NEW

Increase your jobsite solutions with this unique cordless magdrill, the most compact & lightweight unit in its class. Market-leading 140mm stroke which is ideal for extra-long broach cutters and VersaDrive® cutting tools.

The 18V, 9Ah battery pack is compatible with the entire range of Makita LXT powertools.

Permanent magnet provides safe & powerful hold, even on thin materials, eliminating any risk of power failure to the magnet.



### FEATURES & BENEFITS

- Available with **STAKIT** sitecase & 2 9.0Ah batteries or Bare machine
- Compatible with Makita LXT batteries
- Up to 49 x 18mm holes per charge (10mm plate)
- Weighs just 9.8kg for easy handling

### TECHNICAL SPECIFICATIONS

CUTTER SIZE RANGE	12 - 36mm TCT
MAX CUTTER LENGTH	110mm
TWIST DRILL CAPACITY	1 - 13mm
COUNTERSINKING	10 - 25mm
REAMING	N/A
TAPPING	N/A
LENGTH	325mm
WIDTH (Inc Handles)	184mm
HEIGHT (Min-Max)	275 - 415mm
STROKE	140mm
WEIGHT	9.8 kg
MAGNET (L X W)	157 x 85mm
MAGNETIC ADHESION	650 kgs
MOTOR POWER	1000w
TOTAL POWER	1000w
SPEED RPM (No Load)	530
SPINDLE	3/4" Weldon
ARBOR	Integral 3/4" Weldon
COOLANT SYSTEM	Optional Extra
WARRANTY	1yr
BATTERY CAPACITY	18V 5Ah / 9Ah Li-ion

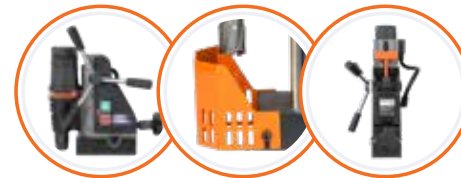

Part No	Contents
805036-010	V36-18 Magnet Drill - Bare Machine
805036-020	V36-18 Magnet Drill Kit - Inc. 2 x 9AH Batteries + Charger
805036-030	V36-18 Magnet Drill Battery 9.0AH
805036-040	V36-18 Magnet Drill Charger

Kit supplied in **STAKIT Base 200** case, with **Rapid-Lock VersaDrive®** adapter, 2 batteries & battery charger\*





# HMT RTQ40 Low Profile Magnet Drill



The HMT RTQ40 is a low profile Magnet Drill for tight access applications.

Designed to fit into any space greater than 180mm it is suitable for use with any standard broaching cutters but is optimised to work with the high-performance CarbideMax 40 cutters. The ratchet drive can be mounted on either side of the machine and its powerful motor and magnet give excellent stability.



## FEATURES & BENEFITS

- Fits into spaces 180mm or greater
- Quick release weldon arbor for keyless use
- Ratchet handle can be used on both sides of machine

## TECHNICAL SPECIFICATIONS

CUTTER SIZE RANGE	12-40mm
MAX CUTTER CAPACITY	40mm
TWIST DRILL CAPACITY	13mm
LENGTH	310mm
WIDTH	135mm
HEIGHT	180mm
STROKE	40mm
WEIGHT	10.8kg
MAGNET (L x W x H)	160x80x37mm
MAGNETIC FORCE	1200kg
MOTOR POWER	1050W
TOTAL POWER	1100W
SPEED RPM (No Load)	700RPM
SPINDLE	Quick change 19.05mm 3/4" Weldon arbor for all standard broaching cutters
COOLANT SYSTEM	Gravity Oil Fed
WARRANTY	1 Year



Part No	Contents
803084-110	RTQ40 Magnetic Drill 110v
803084-230	RTQ40 Magnetic Drill 230v



Supplied in STAKIT Base 200 case with hex keys, restraint strap, ratchet and removable coolant system.

# HMT V50 Magnet Drill



NEW

Market leading power-to-weight ratio. This powerful 1200w, 2 speed magnetic drill is designed for all day drilling duties

The market-leading 160mm stroke length is ideal for extra-long broach cutters and VersaDrive® cutting tools

Supplied with STAKIT sitecase, accessory pack & VersaDrive® weldon adapter as standard



## FEATURES & BENEFITS

- High power to weight 2 speed machine
- Perfect cutting up to 50mm diameter
- 160mm stroke for long cutters and reamers

## TECHNICAL SPECIFICATIONS

CUTTER SIZE RANGE	12 - 50mm TCT
MAX CUTTER LENGTH	150mm
TWIST DRILL CAPACITY	1 - 18mm
COUNTERSINKING	32mm
REAMING	18mm
TAPPING	N/A
LENGTH	270mm
WIDTH (Inc Handles)	165mm
HEIGHT (Min-Max)	400 - 560mm
STROKE	160mm
WEIGHT	12.7 kg
MAGNET (L X W)	167 x 80 x 50mm
MAGNETIC ADHESION	1250 kgs
MOTOR POWER	1200w
SPEED RPM (No Load)	400 / 720
SPINDLE	3/4" Weldon
ARBOR	Integral 3/4" Weldon
COOLANT SYSTEM	Gravity Oil Fed
WARRANTY	2 Yrs (When registered)



Part No	Contents
850050-110	V50 Magnetic Drill Kit 110V
850050-230	V50 Magnetic Drill Kit 230V



Supplied in STAKIT Base 200 case, with Rapid-Lock VersaDrive® adapter

# HMT V35 Pipe Magnet Drill



The V35 Pipe Magnet Drill offers all the advantages of the standard V35 with the added benefit of a pipe compatible magnetic base.

Two switched permanent magnets are secured to swivelling mounting points and can be positioned as needed, allowing use on tubes and piping with a minimum diameter of 76mm. This also allows use on many contoured surfaces and internal use on large pipes.

Magnets can also be positioned horizontally to use as a standard machine on flat surfaces.



## FEATURES & BENEFITS

- Use on both contoured and flat surfaces
- Two switched permanent magnets with individual swivel action
- Use on pipe/tubing internally and externally as needed (min diameter 76.2mm)
- Supplied with coolant fed arbor

## TECHNICAL SPECIFICATIONS

CUTTER SIZE RANGE	12 - 35mm TCT
MAX CUTTER CAPACITY	35mm
MAX CUTTER LENGTH	110mm
TWIST DRILL CAPACITY	12mm
COUNTERSINKING	25mm
REAMING	N/A
MAX TAP CAPACITY	N/A
STROKE	140mm
LENGTH	275mm
WIDTH (Inc Handles)	185mm
HEIGHT (Min-Max)	330 - 470mm
WEIGHT	10.5kg
MAGNET (L X W X H)	187 x 165 x 83mm
MAGNETIC ADHESION	532kg
MOTOR POWER	850W
TOTAL POWER	900W
SPEED RPM (No Load)	750
SPINDLE	3/4" Weldon
ARBOR	Integral 3/4" Weldon
COOLANT SYSTEM	Gravity Oil Fed
WARRANTY	2 Year (When registered)



Part No	Contents
850035-T-110	V35 PIPE Magnet Drill Kit 110V
850035-T-230	V35 PIPE Magnet Drill Kit 230V



Supplied with STAKIT case, VersaDrive® Rapid-Lock adapter, handles, restraint strap, heavy duty metal guard & gravity fed coolant system.



# HMT V60T Pipe Magnet Drill



The V60T Pipe Magnet Drill offers all the advantages of the standard V60T with the added benefit of a pipe compatible magnetic base.

Two switched permanent magnets are secured to swivelling mounting points and can be positioned as needed, allowing use on tubes and piping with a minimum diameter of 80mm. This also allows use on many contoured surfaces and internal use on large pipes.

Magnets can also be positioned horizontally to use as a standard machine on flat surfaces.



## FEATURES & BENEFITS

- Use on both contoured and flat surfaces
- Two switched permanent magnets with individual swivel action
- Use on pipe/tubing internally and externally as needed (min diameter 80mm)
- Supplied with coolant fed arbor

## TECHNICAL SPECIFICATIONS

CUTTER SIZE RANGE	12 - 60mm TCT
MAX CUTTER CAPACITY	60mm TCT
MAX CUTTER LENGTH	150mm
TWIST DRILL CAPACITY	20mm
COUNTERSINKING	40mm
REAMING	20mm
MAX TAP CAPACITY	M20
LENGTH	320mm
WIDTH (Inc Handles)	220mm
HEIGHT (Min-Max)	415 - 635mm
STROKE	220mm
WEIGHT	19 kg
MAGNET (L X W)	266 x 239 x 82mm
MAGNETIC ADHESION	860kg
MOTOR POWER	1150W
TOTAL POWER	1270W
SPEED RPM (No Load)	100 - 250 / 180 - 450
SPINDLE	MT2
ARBOR	19.05 mm (3/4") Weldon
COOLANT SYSTEM	Gravity Oil Fed
WARRANTY	2 Year (When registered)



Part No	Contents
850060-T-110	V60T PIPE Twin Magnet Drill Kit 110v
850060-T-230	V60T PIPE Twin Magnet Drill Kit 230v



Supplied with case, VersaDrive® Rapid-Lock adapter, morse taper broaching arbor, handles, restraint strap, heavy duty metal guard & gravity fed coolant system.



## HMT V60T Magnet Drill

HOLEMAKER TECHNOLOGY  
**HMT**

The HMT V60T is designed to meet a need in the market for a high-performance, low-maintenance, industrial quality portable drilling unit.

The powerful forward/reverse, variable speed, Eibenstock motor will tap holes up to M20 diameter. The V60T is also fully rated for reaming & countersinking.

Advanced British electromagnets provide enhanced magnet hold for exceptional safety and stability. Supplied with a coolant fed arbor.



### FEATURES & BENEFITS

- All-day broaching capability up to 60mm diameter
- Forward and reverse
- Variable speed motor
- 220mm Stroke

### TECHNICAL SPECIFICATIONS

CUTTER SIZE RANGE	12 - 60mm TCT
MAX CUTTER CAPACITY	60mm
MAX CUTTER LENGTH	150mm
TWIST DRILL CAPACITY	20mm
COUNTERSINKING	40mm
REAMING	20mm
MAX TAP CAPACITY	M20
STROKE	220mm
LENGTH	315mm
WIDTH (Inc Handles)	220mm
HEIGHT (Min-Max)	385 - 605mm
WEIGHT	18kg
MAGNET (L X W)	200 x 100mm
MAGNETIC ADHESION	1750kg
MOTOR POWER	1150W
TOTAL POWER	1270W
SPEED RPM (No Load)	100 - 250 / 180 - 450
SPINDLE	MT2
ARBOR	19.05mm (3/4") Weldon
COOLANT SYSTEM	Gravity Oil Fed
WARRANTY	2 Year (When registered)



Part No	Contents
850060-P-110	V60T Magnetic Drill Kit - 110v
850060-P-230	V60T Magnetic Drill Kit - 230v



Supplied with **STAKIT** case, **VersaDrive**® Rapid-Lock adapter, handles, restraint strap, heavy duty metal guard & gravity fed coolant system.



## HMT V85T Magnet Drill

HOLEMAKER TECHNOLOGY  
**HMT**

The HMT V85T combines light weight portability with high power, all-day broaching capability up to 85mm diameter.

The powerful forward/reverse, variable speed, Eibenstock motor will tap holes up to M27 diameter. The V85T is also fully rated for reaming and countersinking. Advanced British electromagnets provide enhanced magnet hold for exceptional safety and stability. Supplied with a coolant fed arbor.



### FEATURES & BENEFITS

- All-day broaching capability up to 80mm diameter
- Forward and reverse
- Variable speed motor
- Variable Torque control

### TECHNICAL SPECIFICATIONS

CUTTER SIZE RANGE	12 - 85mm TCT
MAX CUTTER CAPACITY	85mm TCT
MAX CUTTER LENGTH	150mm
TWIST DRILL CAPACITY	27mm
COUNTERSINKING	55mm
REAMING	24mm
MAX TAP CAPACITY	M27
LENGTH	325mm
WIDTH (Inc Handles)	240mm
HEIGHT (Min-Max)	425 - 645mm
STROKE	220mm
WEIGHT	20.5 kg
MAGNET (L X W)	200 x 100mm
MAGNETIC ADHESION	1750 kgs
MOTOR POWER	1800w
TOTAL POWER	1920w
SPEED RPM (No Load)	60 - 140 / 200 - 470
SPINDLE	MT3
ARBOR	19.05mm (3/4") Weldon
COOLANT SYSTEM	Gravity Oil Fed
WARRANTY	2 Year (When registered)



Part No	Contents
850085-P-110	V85T Magnetic Drill Kit - 110v
850085-P-230	V85T Magnetic Drill Kit - 230v



Supplied with case, **VersaDrive**® Rapid-Lock adapter, morse taper broaching arbor, handles, restraint strap, heavy duty metal guard & gravity fed coolant system.





## HMT V100T Magnet Drill

HOLEMAKER TECHNOLOGY  
**HMT**

The HMT V100T offers high performance, low maintenance industrial drilling with an all-day broaching capacity up to 100mm diameter.

Its powerful forward /reverse, variable speed, geared Eibenstock motor will tap holes up to M30 and can be used with the VersaDrive® blind hole tapping system up to M30. The V100T is also fully rated for reaming and countersinking. Supplied with a coolant fed arbor.



### FEATURES & BENEFITS

- All-day broaching capability up to 100mm diameter
- Forward and reverse
- Variable speed motor
- Variable Torque control

### TECHNICAL SPECIFICATIONS

CUTTER SIZE RANGE	12 - 100mm TCT
MAX CUTTER CAPACITY	100mm TCT
MAX CUTTER LENGTH	200mm
TWIST DRILL CAPACITY	32mm
COUNTERSINKING	55mm
REAMING	26mm
MAX TAP CAPACITY	M30
LENGTH	345mm
WIDTH (Inc Handles)	240mm
HEIGHT (Min-Max)	450 - 730mm
STROKE	280mm
WEIGHT	24.5 kg
MAGNET (L X W)	220 x 115mm
MAGNETIC ADHESION	2200 kgs
MOTOR POWER	1800w
TOTAL POWER	1900w
SPEED RPM (No Load)	60 - 140 / 200 - 470
SPINDLE	MT3
ARBOR	19,05 mm (¾") Weldon
COOLANT SYSTEM	Gravity Oil Fed
WARRANTY	2 Year (When registered)



Part No	Contents
850100-P-110	V100T Magnetic Drill Kit - 110v
850100-P-230	V100T Magnetic Drill Kit - 230v



Supplied with case, VersaDrive® Rapid-Lock adapter, handles, restraint strap, heavy duty metal guard & gravity fed coolant system.



## HMT V125T Magnet Drill

HOLEMAKER TECHNOLOGY  
**HMT**

The HMT V125T offers heavy duty, portable drilling up to 125mm diameter.

An all day broaching capacity combines with powerful tapping capability up to M32 for both through & blind holes thanks to a powerful forward/reverse, variable speed, multi-gear Eibenstock motor. Advanced British electromagnets also provide enhanced magnet hold for exceptional safety and stability. Supplied with a coolant fed arbor.



### FEATURES & BENEFITS

- All-day broaching capability up to 125mm diameter
- Forward and reverse
- Variable speed motor
- Variable Torque control

### TECHNICAL SPECIFICATIONS

CUTTER SIZE RANGE	12 - 125mm TCT
MAX CUTTER CAPACITY	125mm TCT
MAX CUTTER LENGTH	200mm
TWIST DRILL CAPACITY	32mm
COUNTERSINKING	60mm
REAMING	32mm
MAX TAP CAPACITY	M32
LENGTH	345mm
WIDTH (Inc Handles)	240mm
HEIGHT (Min-Max)	470 - 750mm
STROKE	280mm
WEIGHT	25 kg
MAGNET (L X W)	220 x 115mm
MAGNETIC ADHESION	2200 kgs
MOTOR POWER	1800w
TOTAL POWER	1900w
SPEED RPM (No Load)	60-140 / 100-220 / 140-310 / 210-490
SPINDLE	MT3
ARBOR	19,05 mm (¾") Weldon
COOLANT SYSTEM	Gravity Oil Fed
WARRANTY	2 Year (When registered)



Part No	Contents
850125-P-110	V125T Magnetic Drill Kit - 110v
850125-P-230	V125T Magnetic Drill Kit - 230v



Supplied with case, VersaDrive® Rapid-Lock adapter, morse taper broaching arbor, handles, restraint strap, heavy duty metal guard & gravity fed coolant system.



## HMT MAX150T Magnet Drill

HOLEMAKER TECHNOLOGY  
**HMT**

The HMT MAX150T offers immense capacity for portable drilling, tapping and countersinking.

Designed for heavy duty, industrial applications, it tackles the most challenging metalworking tasks with its 2400W, high torque, variable speed, reversible motor.

Broach up to 150mm diameter, drill or ream up to 46mm and countersink up to 90mm.



### FEATURES & BENEFITS

- 4 speed gearbox for low speed, high torque applications
- Lifting eyes for safe positioning of the unit
- Morse Taper 4 spindle with XL Weldon Arbor supplied in kit
- Emergency stop function and safety guard included

### TECHNICAL SPECIFICATIONS

CUTTER SIZE RANGE	12-150mm
MAX CUTTER LENGTH	200mm
MAX TWIST DRILL	46mm
MAX TAPPING SIZE	M42
COUNTERSINKING	90mm
REAMING	46mm
LENGTH	390mm
WIDTH INC HANDLES	210mm
HEIGHT	630-930mm
STROKE	300mm
WEIGHT	42kg
MAGNET SIZE	270x135x70mm
MAGNETIC FORCE	2100kg
POWER CONSUMPTION	2,400W
SPEED RPM (No Load)	60-80//125-165// 205-275//410-545
SPINDLE	MT4
ARBOR	31.75mm (1-1/4") Weldon
COOLANT SYSTEM	Included
WARRANTY	1 Year



Part No	Contents
803094-110	HMT MAX150T Magnet Drill 110v
803094-230	HMT MAX150T Magnet Drill 230v



Supplied with a heavy duty site case, morse taper broaching arbor, handles, restraint strap, heavy duty metal guard & gravity fed coolant system.



## HMT MAX200T Magnet Drill

HOLEMAKER TECHNOLOGY  
**HMT**

The HMT MAX200T offers the world's largest capacity for portable drilling, tapping and countersinking.

Designed for heavy duty, industrial applications, it tackles the most challenging metalworking tasks with its 2850W, high torque, variable speed, reversible motor.

Broach up to 200mm diameter, drill or ream up to 56mm and countersink up to 110mm.



### FEATURES & BENEFITS

- 4 speed gearbox for low speed, high torque applications
- Lifting eyes for safe positioning of the unit
- Morse Taper 5 spindle with XL weldon Arbor supplied in kit
- Emergency stop function and safety guard included

### TECHNICAL SPECIFICATIONS

CUTTER SIZE RANGE	12-200mm
MAX CUTTER LENGTH	200mm
MAX TWIST DRILL	56mm
MAX TAPPING SIZE	M52
COUNTERSINKING	110mm
REAMING	56mm
LENGTH	455mm
WIDTH INC HANDLES	280mm
HEIGHT	730-955mm
STROKE	330mm
WEIGHT	52kg
MAGNET SIZE	295x140x70mm
MAGNETIC FORCE	2700kg
POWER CONSUMPTION	2,850W
SPEED RPM (No Load)	40-60//90-130// 170-240//380-545
SPINDLE	MT5
ARBOR	31.75mm (1-1/4") Weldon
COOLANT SYSTEM	Included
WARRANTY	1 Year



Part No	Contents
803096-110	HMT MAX200T Magnet Drill 110v
803096-230	HMT MAX200T Magnet Drill 230v



Supplied with a heavy duty site case, morse taper broaching arbor, handles, restraint strap, heavy duty metal guard & gravity fed coolant system.



# HMT Cordless Coolant Pump

HOLEMAKER TECHNOLOGY  
**HMT**

4 Litre, rechargeable cordless coolant pump with adjustable dispensing arm, magnetic foot and additional coolant supply outlet that can be connected to a magnet drill arbor. Use for both external flooding and through arbor cooling.

Dispensing arm provides hands-free, adjustable flow lubrication and cooling for otherwise difficult operations.

The magnetic foot can be secured to any magnetic surface for maximum flexibility of use when working at height, in tight, awkward locations or just where two hands are needed for the job and lubrication wouldn't otherwise be possible.

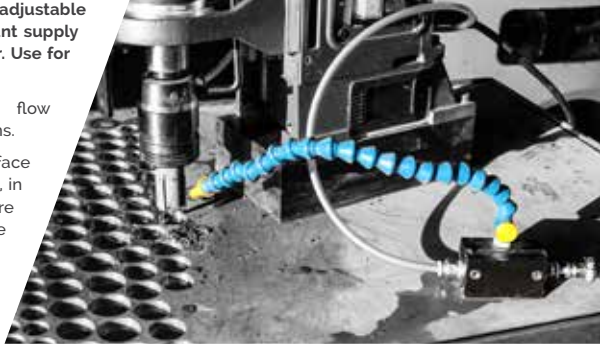

## FEATURES & BENEFITS

- 4 Litre capacity
- Cordless, with integrated rechargeable battery
- Magnetic foot for continuous hands free lubrication
- Can also be used to for through-arbor coolant on magnetic drills.

## TECHNICAL SPECIFICATIONS

LENGTH	320mm (Exc. dispensing arm)
WIDTH	155mm
HEIGHT	260mm
WEIGHT	950g (Empty)
BATTERY	2Ah
BATTERY LIFE	Up to 3hrs
CAPACITY	4 Litres



Part No	Contents
103010-KIT	4L Cordless Coolant Pump Kit



For best results use with BioCut Blue lubricant & room temperature tap water.  
Suggested mix: 0.5L of BioCut Blue to 3.5L water

# HMT OverReach System

HOLEMAKER TECHNOLOGY  
**HMT**

NEW

The HMT OverReach system is a unique Magnetic base, secondary fixturing system designed for use with Magnetic Drills. Overreach provides the capability to reach over, around, and beyond obstructions such as plates or rivet heads which would otherwise prevent convenient access with a conventional Magnetic Drill.

The powerful electromagnet can be positioned further away from the hole & a magnet drill can be placed on the projecting steel plate to give more positioning options. With the adjustable swivel arm fitted, the magnetic base can be mounted up to 300mm from where the magnet drill is required, giving greater flexibility & overcoming otherwise impossible drilling challenges.



## FEATURES & BENEFITS

- NEW OverReach 50 Dual Coil version provides enhanced magnetic adhesion and compatibility with 230 Volt input supply.
- High Strength Magnetic Base
- Industrial Grade swivel, mounting plate
- Swivels through 360 degrees for ultimate positioning flexibility.

## TECHNICAL SPECIFICATIONS

### OverReach 35

MAX CUTTER CAPACITY	35mm
SWIVEL PLATE THICKNESS	20mm
PLATE AREA	400 x 140mm
WEIGHT	12.6kg
TRAVEL	300mm
MAGNET POWER	1100kgs
MAGNET DIMENSIONS	115 x 115mm
MAX WEIGHT SUPPORTED	12kg



861020

### OverReach 50

MAX CUTTER CAPACITY	50mm
SWIVEL PLATE THICKNESS	20mm
PLATE AREA	473 x 140mm
WEIGHT	17.85kg
TRAVEL	300mm
MAGNET POWER	2200kgs
MAGNET DIMENSIONS	220 x 115mm
MAX WEIGHT SUPPORTED	18kg



861025

Minimum base material required for OverReach system - 10mm thick, clean, flat, paint & rust free  
To be used in accordance with operating instructions contained within Manual



Part No	Contents
861020-110	HMT OverReach 35 Magnet Base Clamp with Slide Plate, 110 Volt
861025-110	HMT OverReach 50 Magnet Base Clamp with Slide Plate, 110 Volt
861025-230	HMT OverReach 50 Magnet Base Clamp with Slide Plate, 230 Volt

Supplied in a STAKIT Base 200 case



\*N.B. Minimum cutter length needed for use with the OverReach system - 110mm cutting depth



HSS-XE twist drill bits with integrated Weldon shank for simple and accurate drilling in steel and fast tool changing. Removes the need for using a separate drill chuck in a Magnet Drill.

Where drilling smaller holes in thick steel has been a long and time consuming job in the past, fitting the SilverMax Weldon Shank Twist Drills into a Magnet Drill can suddenly make the job far quicker and safer than struggling with a Pistol Drill and jobber drills.



## FEATURES & BENEFITS

- Integrated weldon shank
- Simple & accurate drilling in steel
- No need for a tool chuck when using a Magnet Drill
- Fast tool changing
- Quicker and safer than struggling with a Pistol Drill
- Fits 19.05mm arbors - use with any standard mag drill

Metric	DØ (mm)	Tap Size
201070-0050	5.0	M6
201070-0060	6.0	-
201070-0068	6.8	M8
201070-0070	7.0	-
201070-0080	8.0	-
201070-0085	8.5	M10
201070-0090	9.0	-
201070-0100	10.0	-
201070-0102	10.2	M12
201070-0110	11.0	-
201070-0120	12.0	-
Inch	DØ (")	Tap Size
201075-0030	1/4	
201075-0050	5/16	3/8"
201075-0060	3/8	
201075-0070	7/16	
201075-0080	1/2	

InsertFoam Sets
201070-SET 6, 8, 10, 12mm
201070-TSET 5, 6.8, 8.5, 10.2mm
201075-SET1 1/4, 5/16, 3/8, 7/16, 1/2"



The MultiSink is a worldwide unique new Combination Countersink Tool designed and developed by HMT for use with Magnetic Drills.

The tool is designed to combine with the VersaDrive® product range to Broach & Countersink, Drill & Countersink, Tap & Countersink or even Drill, Tap & Countersink in one operation - providing huge time-saving benefits.

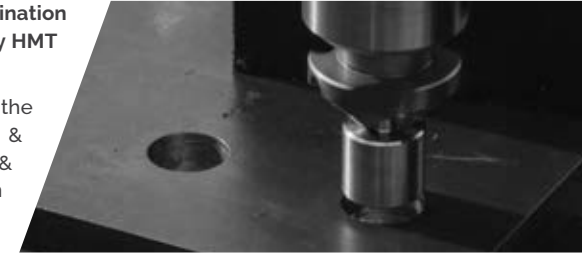

## FEATURES & BENEFITS

FOR DETAILED TECHNICAL ADVICE & RPM GUIDANCE SEE P.128

- Innovative combination countersinking tool
- Save time completing countersunk holes
- Broach/Drill & countersink in one operation
- Suitable for holes 16mm and above
- Pilot feature gives a precise, concentric fit for excellent performance
- Tap & countersink in one operation

Part No	DØ	D2	L	Shank	Point Angle
601055-0400	40mm	14mm	100mm	19.05mm / 3/4"	90°
601055-0550	55mm	14mm	109mm	19.05mm / 3/4"	90°
601057-0010	1-1/2"	9/16"	3-15/16"	3/4" / 19.05mm	82°
601057-0020	2-1/4"	9/16"	4-5/16"	3/4" / 19.05mm	82°

MultiSink Pilots			
Part No	D Ø	Length	Shank
601050-0160	16mm	52mm	11mm
601050-0180	18mm		
601050-0200	20mm		
601050-0220	22mm		
601050-0240	24mm		
601050-0260	26mm	2-3/64"	7/16"
601051-0010	9/16"		
601051-0015	5/8"		
601051-0020	11/16"		
601051-0025	3/4"		
601051-0030	13/16"		
601051-0035	7/8"		
601051-0040	15/16"		



Use MultiSink pilot when countersinking bolt holes from 16 - 26mm diameter. Use MultiSink with variable speed Magnet Drill. The speed must be reduced when countersinking.

## Countersinks

HOLEMAKER TECHNOLOGY  
**HMT**

## Countersinks

HOLEMAKER TECHNOLOGY  
**HMT**

HMT Weldon Shank TCT Countersink



Premium countersink with 3X heavy duty tungsten carbide inserts for maximum life in challenging materials.

Standard 19.05mm Weldon shank for use in all standard Magnet Drills.

Use with a 103013 Morse taper arbor to use in a Pillar Drill or Radial Drill.

Part No	Size	Point Angle
601035-0320	32mm	90°
601037-0010	1-1/4"	82°

HMT ULTRA Weldon Shank TCT Countersink



Premium, ULTRA coated countersink with 3X heavy duty tungsten carbide inserts for maximum life in challenging materials.

Standard 19.05mm Weldon shank for use in all standard Magnet Drills.

Use with a 103013 Morse taper arbor to use in a Pillar Drill or Radial Drill.

For use on materials like Hardox & other wear plate.

Part No	Size	Point Angle
601036-0320	32mm	90°
601038-0010	1-1/4"	82°

HMT Magnet Drill Countersink - 50mm, 60°



High Speed Steel with precision ground flutes.

Standard 19.05mm Weldon shank for use in all standard Magnet Drills.

Part No	Size
601040-0500	50mm

VersaDrive® MultiSink System



The VersaDrive® MultiSink system is available TCT and ULTRA coated versions for accurate, chatter-free, piloted countersinking.

Used in combination with VersaDrive® TurboTips, Cobalt Bits, HoleCutters, ImpactaTaps or DrillTaps significant time savings can be achieved drilling, broaching or tapping and then countersinking in one pass.

See pages 6g & 8g for more information and sizes

GoldMax HSS Weldon Countersink



Specially coated for increased tool life.

Standard 19.05mm Weldon shank for use in all standard Magnet Drills.

Part No	Size	Point Angle
601025-0300	30mm	90°
601025-0400	40mm	90°
601025-0550	55mm	90°
601026-0020	1-1/2"	82°
601026-0030	2"	82°

HMT 90° Carbide Indexable Countersink 76mm



76mm heavy-duty large countersink with Morse Taper shank.

Each countersink is supplied with Premium replaceable carbide inserts for cost effective performance in structural metals.

Supplied with set of 3 tips which are double sided for extended use.

Part No	Product
602040-0760	MT3 Carbide Indexable Countersink
602040-0760R	Single Tungsten Carbide Tip - 2 sided

VersaDrive® Countersinks



Hex-shank countersink for slip free, accurate countersinking Impact rated to 16.5mm for fast, safe, kickback free working

See page 50 for more information and sizes

VersaDrive® DrillSinks



Drill and Countersink in one pass  
Drill bit pilots countersink for best performance

See page 48 for more information and sizes

## Weldon Shank - Morse Taper Arbor 19.05mm



Spring loaded for cutter slug ejection

Part No	Arbor Size	Shank Size
103013-0192	MT2	19.05mm / 3/4"
103013-0193	MT3	19.05mm / 3/4"
103013-0194	MT4	19.05mm / 3/4"
103014-0192	MT2 Internal Cooling Arbor 19.05mm	
103014-0193	MT3 Internal Cooling Arbor 19.05mm	

## Spring Loaded Extension Arbor



Spring Loaded extension arbor for very deep drilling using multiple extension arbors in series. The spring loaded design means only the bottom extension needs to be piloted, with standard cutter pilot pin. Will pass through hole diameters greater than 35mm.

Part No	Extension Length	Shank Size
103095-1000	100mm	19.05mm / 3/4"

## 31.75mm to 19.05mm Weldon Shank Adapter & Pilot



Adapts 31.75mm Shank XL cutters to 19.05mm standard Magnet Drill fitting; includes pilot

Part No	Details
103091-1932-55	19.05 Male to 31.75mm Female Weldon Adapter + Pilot for 55mm cutters
103091-1932-110	19.05 Male to 31.75mm Female Weldon Adapter + Pilot for 110mm cutters

## Standard Weldon Shank Extension Arbor



Will pass through hole diameters greater than 35mm

Part No	Extension Length	Shank Size
103090-0500	50mm	19.05mm / 3/4"
103090-0750	75mm	19.05mm / 3/4"
103090-1000	100mm	19.05mm / 3/4"

## Replacement Set Screws



Part No	Thread Size	Hex Key Size	Unit of sale
103060-0606	M6 x 6	3mm	Pack 10
103060-0808	M8 x 8	4mm	Pack 10
103060-1010	M10 x 10	5mm	Pack 10
103060-1212	M12 x 12	6mm	Pack 10

## 31.75mm Weldon Shank Morse Taper Arbor & Pilot



Spring loaded for cutter slug ejection

Part No	Arbor Size	Shank Size
103013-0323	MT3	31.75mm / 1 1/4"
103013-0324	MT4	31.75mm / 1 1/4"

## Morse Taper Sleeve



Morse Taper sleeve reducers have a smaller internal taper size than the machine (drive) end, to allow a smaller morse taper to be fitted. Hardened and ground high precision specification.

Part No	Size
103615-R21	MT2 outside, MT1 Inside
103615-R32	MT3 outside, MT2 Inside
103615-R43	MT4 outside, MT3 Inside
103615-R53	MT5 outside, MT3 Inside
103615-R54	MT5 outside, MT4 Inside

## Morse Taper Drifts



Tapered steel drifts for simple removal of Morse Taper arbors, drill bits and tooling from MT2, MT3 or MT4 machine spindles

Part No	Suits
103012-0002	MT1 & MT2
103012-0003	MT3
103012-0004	MT4

## Magnetic Swarf Lifter



Part No	Total Length	Magnet Length
103011-0001	400mm	180mm

## Morse Taper Extension



Morse Taper Extensions have an Internal and an External Morse Taper and are used to extend the reach of Magnet Drill Arbors and enable the use of tooling with different size shanks. Hardened and ground high precision specification.

Part No	Size
103616-E32	MT3 outside, MT2 inside
103616-E33	MT3 outside, MT3 inside
103616-E34	MT3 outside, MT4 inside
103616E-E43	MT4 outside, MT3 inside
103616-E44	MT4 outside, MT4 inside

## Heavy Duty Magnet Drill Chuck & Adapter

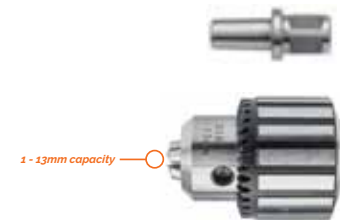

1 - 13mm capacity

Part No	Description	Fitting Type
103017	Chuck Adapter	19.05mm / 3/4"
103070	Keyed Chuck	1/2" Chuck - B16 taper

## Weldon Quick Change Morse Taper Magnet Drill Arbor



Weldon Morse Taper Arbor with a smooth action, rotating collar and push-release action to allow rapid tool or adapter loading and unloading without the need for fiddly, time consuming grub screws or Allen keys. Takes 19.05mm (3/4") Magnet Drill Weldon fitting.

Part No	Description
103016-0192	MT2 Quick change arbor
103016-0193	MT3 Quick change arbor



## GoldMax Tungsten Carbide Burrs

### GoldMax TCT Burr - Flame



Standard 6mm Shank

Part No	Head Dimension	Total Length
402050-0060	6 x 16mm	60mm
402050-0120	12 x 25mm	70mm

### GoldMax TCT Burr - Ball Nose



Standard 6mm Shank

Part No	Head Dimension	Total Length
402020-0060	6 x 16mm	60mm
402020-0120	12 x 25mm	69mm

### GoldMax TCT Burr - Tree



Standard 6mm Shank

Part No	Head Dimension	Total Length
402060-0060	6 x 16mm	60mm
402060-0120	12 x 25mm	69mm

### GoldMax TCT Burr - Cylinder End Cut



Standard 6mm Shank

Part No	Head Dimension	Total Length
402040-0060	6 x 16mm	60mm
402040-0120	12 x 25mm	69mm

### GoldMax TCT Burr - Ball



Standard 6mm Shank

Part No	Head Dimension	Total Length
402010-0060	6 x 6mm	50mm
402010-0120	12 x 10mm	55mm

### GoldMax TCT Burr - 4 Piece Set



4 Piece set contains Flame, Cylinder, Ball Nose and Tree Burrs in 6 or 12mm head diameter

Part No	Head Dimension
4020-SET2	6mm
4020-SET1	12mm

## Metal Cutting Lubricants

### SpeedLube™ Lubricant Spray



SpeedLube™ is a high performance foaming lubricant suitable for a wide variety of metal drilling applications across a range of materials including stainless steel.

Aerosol propellant ensures the lubricant foams on contact to ensure maximum tool coverage and heat dissipation. Easy one-handed application provides fast, efficient lubricant coverage and minimises the amount of applications needed during the drilling process. Unique 360° valve which enables SpeedLube to be sprayed from all angles.

Part No	Aerosol Size	Unit of Sale
701010-0002	500ml	Each
701010-0002-P12	500ml	Pack of 12
701010-0002-144	500ml	12 Packs of 12
701010-0002-432	500ml	36 Packs of 12

### AeroPaste™ Lubricant Spray



AeroPaste™ is an aerosol applied paste-type, metalworking lubricant for hole broaching, tapping, reaming & drilling applications. Ideal for overhead or positional application, the high viscosity of AeroPaste allows it to cling directly to the cutting tool or steel it is applied to, without fluid run-off.

Ideal for use in environmentally sensitive areas such as above water. Using AeroPaste minimises repainting or galvanising issues caused by conventional soluble lubricants and reduces mess and slipping hazards.

Part No	Aerosol Size	Unit of Sale
701010-0001	500ml	Each
701010-0001-P12	500ml	Pack of 12

### BioCut Blue Neat Broaching Oil



BioCut Blue is a ultra high-performance cutting fluid designed for metal fabrication broaching, cutting, and drilling tasks.

- Water-soluble fluid supplied ready-for-use.
- Inherently bio-degradable, can be 100% removed with water.
- Synthetic based, chlorine free, with zero mineral oils.
- No adverse affects for welding and galvanising.
- Excellent performance on Stainless Steel & Hardox type materials

Part No	Bottle Size	Unit of Sale
704010-0001	5 Litres	Each
704010-0001-P4	5 Litres	Box of 4
704010-0002	500ml Bottle	Each
704010-0002-P20	500ml Bottle	Box of 20

### BioCut Paste - Drilling & Tapping Paste



BioCut Drilling & Cutting paste is specifically formulated for superb performance when used with HMT Impact Wrench cutting tools. Extreme pressure concentration provides accurate hole lubrication. Excellent general purpose paste lubricant when drilling, tapping, countersinking, reaming and broaching. Chlorine Free for safer use. Suitable for use with all grades of steel including Stainless Steel & Aluminium.

Part No	Aerosol Size	Unit of Sale
704030-0001	250g	Each
704030-0001-P16	250g	Pack of 16

## Empty ETOP2 Half Top Case

Build your own personalised toolkit with the ETOP2 Half case. The ultimate in portability & lightweight, easy to transport tooling protection, the ETOP2 fits 2 x Small InsertFoams or 1 x Large InsertFoam



**L x W x H (mm) - 270 x 370 x 95**

Part No	Set contents
MKC-ETOP2	Empty <b>STAKIT</b> ETOP2 Half Top Case



## Empty ETOP4 Full Top Case

The ETOP4 Top case gives complete freedom when creating your own unique toolkit. Choose between: 4 x Small InsertFoams or 2 x Large InsertFoams or 2 x Small InsertFoams + 1 x Large InsertFoam



**L x W x H (mm) - 540 x 390 x 95**

Part No	Set contents
MKC-ETOP4	Empty <b>STAKIT</b> ETOP4 Full Top Case



## VersaDrive® InsertFoam for adapters - 5 spaces



Part No	Product
SETFM-ADP-05	VersaDrive® Adapter Small InsertFoam

## VersaDrive® InsertFoam for long series tools - 3 spaces



Part No	Product
SETFM-LS-03	VersaDrive® Long Series Tools InsertFoam

## VersaDrive® STAKIT Small InsertFoam - 7 spaces

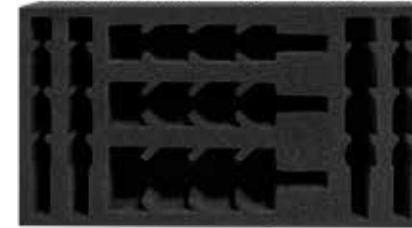

Part No	Product
SETFM-VSD-07	VersaDrive® InsertFoam Small - 7 Spaces

## VersaDrive® STAKIT Small InsertFoam - 8 spaces

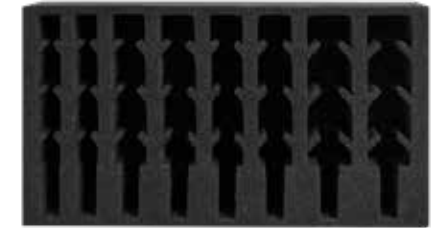

Part No	Product
SETFM-VSD-08	VersaDrive® InsertFoam Small - 8 Spaces

## VersaDrive® Rapid-Lock Adapter Set



Part No	Product
111005-SET1	VersaDrive® Rapid-Lock Adapter InsertFoam Set 4pc

## VersaDrive® Heavy-Duty Adapter Set



Part No	Product
111005-SET2	VersaDrive® HD Adapter InsertFoam Set 4pc

## CarbideMax STAKIT Small InsertFoam - 5 spaces

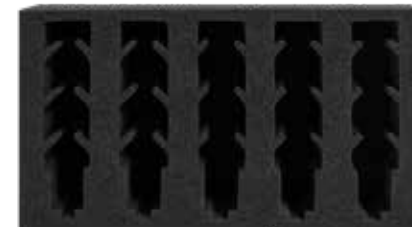

Part No	Product
SETFM-WLD-05	CarbideMax InsertFoam Small - 5 Spaces

## VersaDrive® STAKIT Large InsertFoam - 6 spaces

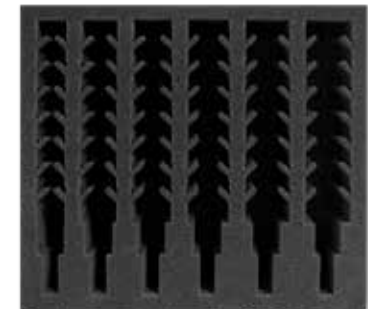

Part No	Product
SETFM-LS-06	VersaDrive® Long Series Tools InsertFoam 6 Spaces

VersaDrive® TCT HoleCutter Sets

VersaDrive® Cobalt Drill InsertFoam Sets

VersaDrive® TurboTip Drill Bit Sets

VersaDrive® TurboTip Drill Bit Sets



Part No	Set contents
101030-SET1	14, 18 & 22mm
101030-SET2	14, 17, 18, 21 & 22mm
101030-INSET1	9/16, 11/16, 13/16"
101030-INSET2	9/16, 11/16, 13/16, 15/16, 1-1/16"

Part No	Set contents
209010-SET1	6,8,10,12mm
209010-SET3	5,6,6.8,8.0,8.5,10,10.2mm
209010-SET6	5, 6, 6.8, 7, 7.5, 8, 9, 10mm

Part No	Set contents
209015-SET1	6, 8, 10, 12mm
209015-SET2	6, 7, 8, 9, 10, 11, 12mm
209015-SET3	6.8, 8, 8.5, 10, 10.5, 12, 14mm

Part No	Set contents
209015-SET4	6, 8, 10, 12, 14, 18, 22mm

VersaDrive® Extra Long TCT HoleCutter Set

VersaDrive® Cobalt Drill InsertFoam Sets

VersaDrive® TurboTip Drill Bits

VersaDrive® TurboTip Drill Bits



Part No	Set contents
101035-SET1	14, 18, 20, 22, 24 & 26mm

Part No	Set contents
209010-SET4	12, 13, 14, 16, 18, 20, 22mm
209010-SET7	10.2, 11.5, 12, 13, 14, 16, 18mm

Part No	Set contents
209015-SET7	11, 12, 13, 14, 16, 18, 20mm
209015-SET6	6, 6.8, 7, 8, 8.5, 9, 10, 10.5mm

Part No	Set contents
209016-SET1	3/16, 1/4, 5/16, 1/2"
209016-SET2	#7, #F, 5/16, 27/64"

VersaDrive® Spiral Flute ImpactaTaps

VersaDrive® DrillTap & Countersink Combination Sets

VersaDrive® Impact Step Drills

VersaDrive® ImpactaStep Cutters



Part No	Set contents
309010-SET1	M6, M8, M10, M12, M16
309010-SET2	M12, M16, M20, M24
309020-SET1	1/4, 5/16, 3/8, 1/2, 5/8" UNC
309020-SET2	1/2, 3/4, 1" UNC

Part No	Set contents
306025-SET1	M6, M8, M10, M12 DrillTaps + 12.4, 16.5, 20.5, 25mm Countersinks
306026-SET1	1/4, 5/16, 3/8, 1/2" DrillTaps + 1/4, 3/8, 1/2" Countersink

Part No	Set contents
505020-SET1	12, 22, 30mm
505020-SET2	12, 22, 30, 40mm
505030-SET1	1/2, 7/8, 1-3/8"

Part No	Set contents
506010-SET1	16, 22, 26mm
506010-SET2	16, 22, 26, 32mm
506030-SET1	9/16, 13/16, 1-1/16"



*VersaDrive® ImpactaTap Sets - Metric Coarse & UNC*



Part No	Set contents
308010-SET1	M6, M8, M10, M12, M16
308010-SET2	M12, M16, M20, M24
308050-SET1	1/4, 5/16, 3/8, 1/2, 5/8" UNC
308050-SET2	1/2, 5/8, 3/4, 1" UNC

*VersaDrive® ImpactaTap Set - Metric Coarse*



Part No	Set contents
308010-SET3	M6, M8, M10, M12, M16, M20, M24

*VersaDrive® Impact Reamer Sets*



Part No	Set contents
501030-3SET	14, 18, 22mm
501040-3SET	1/2, 5/8, 3/4"

*VersaDrive® Impact Reamer Sets*



Part No	Set contents
501030-SET3	8, 10, 12, 14, 16, 18mm
501030-SET4	18, 20, 21, 22, 24, 26mm

*VersaDrive® ImpactaTaps - Oversized Galv Set*



Part No	Set contents
308020-SET1	Oversized Galv Taps for M5, M6, M8, M10, M12, M16

*VersaDrive® DrillTap Sets*



Part No	Set contents
301125-SET1	M5, M6, M8, M10, M12
301126-SET1	1/4, 5/16, 3/8, 1/2" UNC

*VersaDrive® Impact Reamer Sets*



Part No	Set contents
501030-SET	12, 14, 18, 22, 26mm
501040-5SET	1/2, 5/8, 3/4, 7/8, 1-1/16"

*VersaDrive® DrillSink Set*



Part No	Set contents
603070-SET4	8/12.4, 10/16.5, 12/20.5, 14/25mm

*VersaDrive® Heavy Duty Drill Tap Sets*



Part No	Set contents
301130-SET1	M12, M16, M20, M24
301130-SET2	M8, M10, M12, M16, M20, M24
301140-SET1	1/2, 5/8, 3/4, 1" UNC

*VersaDrive® Combination TurboTip & ImpactaTap Set*



Part No	Set contents
328015-SET1	6.8, 8.5, 10.5, 14mm TurboTips + M8, M10, M12, M16 ImpactaTaps
328016-SET2	#7, #F, 5/16, 27/64" TurboTips + 1/4, 5/16, 3/8, 1/2" ImpactaTaps

*VersaDrive® Countersink Sets*



Part No	Set contents
603060-5SET	12.4, 16.5, 20.5, 25, 31mm
603065-5SET	3/8, 1/2, 5/8, 3/4, 1"

*VersaDrive® DrillSink & ImpactaTap Combination Set*



Part No	Set contents
328020-SET1	6.8, 8.5, 10.2mm DrillSinks & M8, M10, M12 ImpactaTaps

VersaDrive & CarbideMax Starter set - 14-30mm



Part No	Set contents
101080-SS1	14, 18, 20, 22, 26, 30mm VersaDrive HoleCutters + 14, 18, 20, 22, 26, 30mm CarbideMax Broach Cutters + 2 Pilots

VersaDrive & CarbideMax Starter set - 13-26mm



Part No	Set contents
101080-SS2	13, 17, 19, 21, 22, 25mm VersaDrive HoleCutters + 12, 14, 18, 20, 22, 26mm CarbideMax Broach Cutters + 2 Pilots

CarbideMax® 40 Broach Cutter Sets



Broaches up to 35mm thickness of metal.

Part No	Set contents
108030-SET	14, 18, 22mm + 2 Pilots
108030-5SET	12, 14, 18, 22, 26mm + Pilots

CarbideMax® 50 Broach Cutter Set



Broaches up to 50mm thickness of metal.

Part No	Set contents
108020-SET	14, 18, 22mm + 2 Pilots
108020-5SET	12, 14, 18, 22, 26mm + Pilots

Broaching InsertFoam Starter Set 5-26mm



Part No	Set contents
108030-SS1	6, 8, 10, 10.2, 12mm Weldon Twist Drills + 14, 18, 20, 22, 24, 26mm CarbideMax Broach Cutters + 2 Pilots + 30mm GoldMax Countersink

VersaDrive® DrillSink / Countersink Starter Set 8-31mm



Part No	Set contents
603067-SET1	8, 10, 11, 12, 13, 14mm DrillSinks + 10.4, 12.4, 16.5, 20.5, 25, 31mm Countersinks Broach Cutters + 2 Pilots + 30mm GoldMax Countersink

CarbideMax® 80 Broach Cutter Set



Broaches up to 75mm thickness of metal.

Part No	Set contents
108010-SET	18, 22, 24, 26, 28, 30mm + 2 pilots

CarbideMax® 110 Broach Cutter Set



Broaches up to 105mm thickness of metal.

Part No	Set contents
108040-SET	14, 18, 22, 24, 26mm + 2 Pilots

## STAKIT ETOP2 Starter Kit

Compact but fully stocked, the ETOP2 Starter Kit provides all the most commonly needed sizes of drilling, tapping and enlarging tools for hole creation and modification in the field.

Connects to **STAKIT** ETOP2 and ETOP4 cases

### Metric Kit Contents:

4 x TurboTips 6.8, 8.5, 10.5, 14mm  
 4 x ImpactaTaps M8, M10, M12, M16  
 3 x ImpactaStep Cutters 8-16, 14-22, 18-26mm  
 1 x VersaDrive® 1/2" Rapid-Lock Impact Wrench Adapter  
 1 x VersaDrive® 130mm Extension Arbor  
 1 x **STAKIT** ETOP2 Half Top Case

### Inch Kit Contents:

4 x TurboTips #7, #F, 5/16, 27/64"  
 4 x ImpactaTaps 1/4, 5/16, 3/8, 1/2"  
 3 x ImpactaStep Cutters 9/16, 13/16, 1-1/16"  
 1 x VersaDrive® 1/2" Rapid-Lock Impact Wrench Adapter  
 1 x VersaDrive® 5" Extension Arbor  
 1 x **STAKIT** ETOP2 Half Top Case

L x W x H (mm) - 270 x 370 x 95

Part No	Product
STC-ETOP2-IMPACT	ETOP2 Starter Kit - Metric Sizes
STC-ETOP2-IK01	ETOP2 Starter Kit - Inch Sizes



## STAKIT®

## STAKIT ETOP4 Starter Kit

Create, enlarge and tap holes using Impact Wrenches with the NEW **STAKIT** ETOP4 Impact Kit.

The perfect kit for steel erectors, snaggers and site crews looking to keep the job moving.

Connects to **STAKIT** ETOP2, ETOP4 and EMID cases

### Metric Kit Contents:

7 x TurboTips 6.8, 8, 8.5, 10, 10.5, 12, 14mm  
 5 x ImpactaTaps M6, M8, M10, M12, M16  
 3 x Impact Reamers 14, 18, 22mm  
 2 x ImpactaStep Cutters 8-16, 18-26mm  
 1 x VersaDrive® 1/2" Rapid-Lock Impact Wrench Adapter,  
 1 x VersaDrive® 130mm Extension Arbor  
 1 x **STAKIT** ETOP4 Full Top Case

### Inch Kit Contents:

4 x TurboTips #7, #F, 5/16, 27/64"  
 5 x ImpactaTaps 1/4, 5/16, 3/8, 1/2, 5/8"  
 3 x Impact Reamers 9/16, 11/16, 13/16"  
 2 x ImpactaStep Cutters 9/16, 13/16"  
 1 x VersaDrive® 1/2" Rapid-Lock Impact Wrench Adapter,  
 1 x VersaDrive® 5" Extension Arbor  
 1 x **STAKIT** ETOP4 Full Top Case

L x W x H (mm) - 540 x 390 x 95

Part No	Product
STC-ETOP4-IMPACT	ETOP4 Impact Kit - Metric Sizes
STC-ETOP4-IK02	ETOP4 Impact Kit - Inch Sizes



## STAKIT ETOP2 TurboTip Kit

The most comprehensive TurboTip Impact drill bit sets to date, supplied in a handy, stacking ETOP2 **STAKIT** kit case.

Connects to **STAKIT** ETOP2 and ETOP4 cases

### Metric Kit Contents:

16 x TurboTips 6, 6.8, 7, 8, 8.5, 9, 10, 10.5,  
 11, 12, 13, 14, 16, 18, 22mm  
 1 x **STAKIT** ETOP2 Half Top Case

### Inch Kit Contents:

12 x TurboTips 3/16, #7, 7/32, 1/4, #F, 9/32,  
 5/16, 11/32, 3/8, 27/64, 7/16, 1/2"  
 1 x **STAKIT** ETOP2 Half Top Case

Upgrade to the full range of 18 fractional TurboTip sizes with the 209016-SET3 in an ETOP4 case

209016-SET3 includes 17/32, 9/16, 5/8, 11/16, 3/4, 13/16"

L x W x H (mm) - 270 x 370 x 95

Part No	Product
209015-SET16	ETOP2 TurboTip Impact Drill Bit Set 6-22mm (16pcs)
209016-SET12	ETOP2 TurboTip Impact Drill Bit Set 3/16 - 1/2" (12pcs)



## STAKIT ETOP4 Reamer Kit

The ultimate VersaDrive® Impact Reamer set, providing every metric or fractional sized reamer in a handy, stacking ETOP4 **STAKIT** kit case.

Connects to **STAKIT** ETOP2, ETOP4 and EMID cases

### Metric Kit Contents:

11 x Impact Reamers 8, 10, 12, 14, 16, 18,  
 20, 21, 22, 24, 26mm  
 1 x **STAKIT** ETOP4 Full Top Case

### Inch Kit Contents:

10 x Impact Reamers 1/2, 9/16, 5/8, 11/16,  
 3/4, 13/16, 7/8, 15/16, 1, 1-1/16"  
 1 x **STAKIT** ETOP4 Full Top Case

L x W x H (mm) - 540 x 390 x 95

Part No	Product
501030-SET11	ETOP4 Impact Reamer Set 8-26mm (11pcs)
501040-SET10	ETOP4 Impact Reamer Set 1/2 - 1-1/16" (10pcs)





## STAKIT Steel Erector's Snagging Kit

STAKIT®

## STAKIT Site Installation Kit

STAKIT®

The Steel Erector's Snagging Kit is a heavy duty site kit for hole creation, enlarging and aligning at all the most commonly required sizes. Comes complete with all pilot pins and hex keys needed for Broach cutters and HoleCutters.

Connects to **STAKIT** ETOP4, EMID and base cases

### Metric Kit Contents:

4 x HoleCutters	14, 18, 22, 26mm
4 x Impact Reamers	14, 18, 22, 26mm
2 x ImpactaStep Cutters	14-22, 18-26mm
4 x Broach Cutters	14, 18, 22, 26mm
1 x VersaDrive® Heavy Duty ½" Impact Wrench Adapter	
1 x VersaDrive® Heavy Duty ¾" Heavy Duty Impact Wrench Adapter	
1 x VersaDrive® 130mm Extension Arbor	

### Inch Kit Contents:

4 x HoleCutters	9/16, 11/16, 13/16, 15/16"
4 x Impact Reamers	9/16, 11/16, 13/16, 15/16"
2 x ImpactaStep Cutters	13/16, 1-1/16"
4 x Broach Cutters	9/16, 11/16, 13/16, 15/16"
1 x VersaDrive® Heavy Duty ½" Impact Wrench Adapter	
1 x VersaDrive® Heavy Duty ¾" Heavy Duty Impact Wrench Adapter	
1 x VersaDrive® 5" Extension Arbor	

L x W x H (mm) - 582 x 387 x 131

Part No	Product
STC-EMID-SEIK	Steel Erector's Snagging Kit - Metric Sizes
STC-EMID-IWSK	Steel Erector's Snagging Kit - Inch Sizes

## STAKIT SiteCart

The **STAKIT** SiteCart is a wheeled base unit with adjustable height handle and robust, water and dust proof construction.

The case can be used on its own for large equipment storage or combined with the rest of the **STAKIT** system to transport tooling and cases to and around the job site or workshop.

The case is designed to be tilted and pulled, has a handy narrow size and is easy to manoeuvre. Supplied empty.



L x W x H (mm) - 600 x 460 x 765

Part No	Product
STC-SITECART	STAKIT SiteCart



The **STAKIT** Site Installation Kit combines an essential set of best-selling VersaDrive® products to overcome all common site installation and steel erection holemaking challenges.

Keeps the job moving when you find an unexpected challenge.

Presented in an interlocking, stackable, and protective **STAKIT** EMID Case.

Connects to **STAKIT** ETOP4, EMID and Base cases

### Metric Kit Contents:

6 x TurboTips	6, 6.35, 8, 10.5, 12, 14mm
5 x HoleCutters	14, 17, 18, 20, 22mm
4 x Impact Reamers	12, 14, 18, 22mm
3 x Impact DrillTaps	M6, M8, M10
3 x ImpactaTaps	M12, M16, M20
2 x ImpactaStep Cutters	8-16, 14-22mm

### Inch Kit Contents:

6 x TurboTips	1/4, 9/32, 5/16, 3/8, 7/16, 1/2"
5 x HoleCutters	9/16, 5/8, 3/4, 7/8, 1"
4 x Impact Reamers	1/2, 9/16, 11/16, 13/16"
3 x Impact DrillTaps	5/16, 3/8, 1/2"
3 x ImpactaTaps	1/2, 5/8, 3/4"
2 x ImpactaStep Cutters	9/16, 13/16"

### + 5x Rapid Lock VersaDrive® adapters

¼" Impact Driver Adapter, ½" Impact Wrench Adapter, Magnet Drill Adapter, 130mm Extension, 300mm Extension

L x W x H (mm) - 582 x 387 x 131

Part No	Product
STC-EMID-MEIK	VersaDrive® STAKIT Installation Kit - Metric Sizes
STC-EMID-INIK	VersaDrive® STAKIT Installation Kit - Inch Sizes



The V35 Install SiteKit is a lightweight package of portable drilling solutions.

The mains powered V35 magdrill provides single speed, lightweight site drilling. Broach up to 35mm diameter, Drilling to 12mm, Countersinking to 25mm.

The VersaDrive installation kit gives a bestselling selection of cutting tools for overcoming installation and maintenance challenges. Includes the bestselling sizes of Impact Reamers, ImpactaTaps, TurboTip Impact Drillbits, CarbideMax TCT Holesaws, and 5 modular adapters.

The wheeled sitecart gives additional storage space for further tooling. All items clip together securely for safe and efficient transportation around the work area.

**Contents:**

- 1 x **STAKIT** Site Installation Kit (p.107)  
(supplied in **STAKIT** Mid Case)
- 1 x VersaDrive® V35 Magnet Drill (p.74)  
(Supplied in **STAKIT** Base 200 case)
- 1 x **STAKIT** SiteCart (p.106)



Part No	Product
STC-KIT-V35INS-110	<b>STAKIT</b> V35 Install SiteKit - 110v
STC-KIT-V35INS-230	<b>STAKIT</b> V35 Install SiteKit - 230v



The V36 18V Install SiteKit is the ultimate lightweight portable drilling package.

The new Cordless V36 18V magdrill install sitekit offers the ultimate jobsite freedom. Operate away from mains power. Compatible with the Makita LXT battery platform. Broaching capacity to 36mm, drilling to 12mm.

The VersaDrive installation kit gives a bestselling selection of cutting tools for overcoming installation and maintenance challenges. Includes the bestselling sizes of Impact Reamers, ImpactaTaps, TurboTip Impact Drillbits, CarbideMax TCT Holesaws, and 5 modular adapters.

The wheeled sitecart gives additional storage space for further tooling. All items clip together securely for safe and efficient transportation around the work area.

**Contents:**

- 1 x **STAKIT** Site Installation Kit (p.107)  
(supplied in **STAKIT** Mid Case)
- 1 x VersaDrive® V36 Cordless Magnet Drill (p.75)  
(Supplied in **STAKIT** Base 200 case)
- 1 x **STAKIT** SiteCart (p.106)



Part No	Product
STC-KIT-V36INS-2B	<b>STAKIT</b> V36-18 Install SiteKit - c/w 2x9Ah Batteries & Charger



The VersaDrive® **STAKIT** V50 Install SiteKit provides a powerful option for heavy duty steelworking applications.

The mains powered V50 magdrill provides powerful 2 speed site drilling. Broach up to 50mm diameter, Twist drills and Reamers to 18mm, Countersinking to 32mm.

The VersaDrive installation kit gives a bestselling selection of cutting tools for overcoming installation and maintenance challenges. Includes the bestselling sizes of Impact Reamers, ImpactaTaps, TurboTip Impact Drillbits, CarbideMax TCT Holesaws, and 5 modular adapters.

The wheeled sitecart gives additional storage space for further tooling. All items clip together securely for safe and efficient transportation around the work area



**Contents:**

- 1 x **STAKIT** Site Installation Kit (p.107)  
(supplied in **STAKIT** Mid Case)
- 1 x VersaDrive® V50 Cordless Magnet Drill (p.77)  
(Supplied in **STAKIT** Base 200 case)
- 1 x **STAKIT** SiteCart (p.106)

Part No	Product
STC-KIT-V50INS-110	<b>STAKIT</b> V50 Install SiteKit - 110v
STC-KIT-V50INS-230	<b>STAKIT</b> V50 Install SiteKit - 230v



The V60T is the top-of-the range Sitekit offering portable machining capacity that is unrivalled in the market.

The mains powered V60T reversible magdrill has 2 speeds plus dial adjustable torque & speed. This gives tapping capacity to M20, Broaching to 60mm diameter, drilling & reaming to 20mm, & countersinking to 40mm.

The VersaDrive installation kit gives a bestselling selection of cutting tools for overcoming installation and maintenance challenges. Includes the bestselling sizes of Impact Reamers, ImpactaTaps, TurboTip Impact Drillbits, CarbideMax TCT Holesaws, and 5 modular adapters.

The wheeled sitecart gives additional storage space for further tooling. All items clip together securely for safe and efficient transportation around the work area.



**Contents:**

- 1 x **STAKIT** Site Installation Kit (p.107)  
(supplied in **STAKIT** Mid Case)
- 1 x VersaDrive® V60T Magnet Drill (p.80)  
(Supplied in **STAKIT** Base 350 case)
- 1 x **STAKIT** SiteCart (p.106)

Part No	Product
STC-KIT-V60INS-110	<b>STAKIT</b> V60T Install SiteKit - 110v
STC-KIT-V60INS-230	<b>STAKIT</b> V60T Install SiteKit - 230v





Left Handed Pilot Drill Bits	Impact Torque		Bolt Extractor	Impact Torque	
	Grade 8.8 bolts			Grade 8.8 bolts	
	Nm Torque	Ft Lb Torque		Nm Torque	Ft Lb Torque
#3	160	178	#3	140	130
#4	280	207	#4	200	145
#5	300	222	#5	220	160
#6	580	430	#6	430	320
#7	Rotary Only	Rotary Only	#7	500	380

## LEFT HANDED DRILL BITS BEST PRACTICE ADVICE

1. Designed for use in left hand direction (Reverse) only.
2. For best results drilling through hardened bolts and materials, it is recommended to start with a small diameter drill bit and step up to the finished diameter with increasingly larger drill bits
3. Ensure ample application of lubricant (SpeedLube/BioCut Blue) during the drilling process to prevent overheating & work hardening of the fastener.
4. Wherever possible use a scribed or drawn mark to find the exact center of the fastener to be drilled.
5. For best results drill all the way through the bolt/stud before inserting the Screw Extractor
6. Where the application allows, using the Left Hand drills in a reversible Magnet Drill will make the drilling process faster and more stable.
7. For larger diameter drill bit sizes (#6/#7) or when drilling particularly hard materials, using a rotary or magnetic drill may provide better results than an Impact wrench.

## BOLT EXTRACTOR BEST PRACTICE ADVICE

1. Ensure the correct sized pilot hole is drilled into seized bolt using VersaDrive® Left Hand bits
2. Use a soft-faced hammer to securely tap the extractor into pilot hole
3. Attach VersaDrive® Impact Adapter and use on left hand rotation (Reverse Mode)
4. Where possible ensure ample lubricant is applied to the drilled hole and time allowed for the fastener to cool after drilling and to allow the lubricant to penetrate into the drilled hole and threads.
5. To assist with successful extraction it is important that the pilot hole is drilled square to the centre of the fastener to avoid the extractor running off plane when reversing out, and potentially breaking or coming loose.
6. Whilst the VersaDrive extractors are superior to standard stud extractors readily available, it is recognised that stud/fastener extraction is a very challenging task and a complete success cannot be guaranteed in all circumstances. Using heating methods and/or releasing fluids can often assist with the removal process.

## QUICK GUIDE

- Drill correct sized pilot hole in seized bolt using VersaDrive® Left Hand bits
- Use a hammer to securely tap the extractor into pilot hole
- Attach VersaDrive® Impact Adapter and use on left hand rotation

## MORE INFO



GUIDELINE PARAMETERS ONLY - Actual parameters may vary depending on operating conditions



Die Nut Size	Full Thread Cutting	Thread Repair / Cleaning
	Impact Torque Nm	Impact Torque Nm
M6	130	130
M8	240	130
M10	360	130
M12	400	130

Die Nut Size	Impact Torque Ft lb	Impact Torque Ft lb
1/4-20 UNC	105	95
5/16-18 UNC	180	95
3/8-16 UNC	260	95
1/2-13 UNC	330	95

## BEST PRACTICE ADVICE

GUIDELINE PARAMETERS ONLY - Actual parameters may vary depending on operating conditions

1. For best results, before cutting the thread, use the VersaDrive® ImpactaBurr to ensure that the fastener/workpiece has a consistent 60 degree bevel/chamfer.
2. To ensure best results for the life of the Die and avoid the thread cutting unevenly on the fastener/workpiece, ensure the tool is held squarely in alignment with the fastener/workpiece.
3. When cutting a new thread use the Guide collar and Guide to help keep the Die in alignment with the fastener/workpiece.
4. For cleaning/repairing or rethreading applications, the flush collar is intended to allow the die to cut a full length thread.
5. Firm forward pressure is recommended both for starting/cutting the thread and when reversing the tool to remove the Die Threader from the fastener.
6. Ensure regular application of SpeedLube cutting fluid prior to and during the cutting process to minimise heat build up.
7. Take care when handling ImpactaDie and workpiece as threaded components may get very hot.
8. Avoid lateral movement or tilting which can cause damage to the tool.
9. Periodically check Die and ImpactaDie Holder/Collar and remove Swarf as required.
10. When cutting a full thread with the ImpactaDie system it is recommended to use an Impact wrench rather than a rotary drill to avoid potential hand/wrist injury from reaction torque.
11. Ensure the use of appropriate PPE at all times when using cutting tools (Safety Glasses, Gloves etc).
12. Impact wrenches of 3/8, 1/2 or 3/4" square drive are recommended (rather than 1/4" impact drivers).

## QUICK GUIDE

- For fastest & safest performance use on Impact Wrenches
- For best results & to avoid kickback, use the ImpactaDie system with an impact wrench rather than a rotary only drill.
- Hardened grades of material may require increased torque
- Use appropriate lubrication and correct torque to achieve long tool life.

## MORE INFO





Metric Diameter	Structural Steel 500Nm	Structural Steel 1000Nm (High Tensile)	Stainless Steel	Special Alloys (Eg Duplex)	Cast Iron	Aluminium Brass Plastic
	RPM Range					
	32m/Min	18m/Min	12m/Min	32m/Min	16m/Min	30m/Min
4.2mm	2654	1365	1213	682	1820	4625
5mm	2229	1146	1019	573	1529	3885
5.5mm	2027	1042	926	521	1390	3532
6mm	1858	955	849	478	1274	3238
6.5mm	1715	882	784	441	1176	2989
6.8mm	1639	843	749	422	1124	2857
7mm	1592	819	728	409	1092	2775
7.5mm	1486	764	679	382	1019	2590
8mm	1393	717	637	358	955	2428
8.5mm	1311	674	599	337	899	2286
9mm	1238	637	566	318	849	2159
9.5mm	1173	603	536	302	805	2045
10mm	1115	573	510	287	764	1943
10.2mm	1093	562	500	281	749	1905
10.5mm	1062	546	485	273	728	1850
11.5mm	969	498	443	249	665	1689
12mm	929	478	425	239	637	1619
12.5mm	892	459	408	229	611	1554
13mm	857	441	392	220	588	1494
14mm	796	409	364	205	546	1388
16mm	697	358	318	179	478	1214
17.5mm	637	328	291	164	437	1110
18mm	619	318	283	159	425	1079
20mm	557	287	255	143	382	971
21mm	531	273	243	136	364	925
22mm	507	261	232	130	347	883

Inch Diameter	Structural Steel 500Nm	Structural Steel 1000Nm (High Tensile)	Stainless Steel	Special Alloys (Eg Duplex)	Cast Iron	Aluminium Brass Plastic
	RPM Range					
	32m/Min	18m/Min	12m/Min	32m/Min	16m/Min	30m/Min
3/16	2654	1365	1213	682	1820	4625
#7	2229	1146	1019	573	1529	3885
7/32	2027	1042	926	521	1390	3532
1/4	1715	882	784	441	1176	2989
#F	1639	843	749	422	1124	2857
9/32	1592	819	728	409	1092	2775
5/16	1393	717	637	358	955	2428
11/32	1238	637	566	318	849	2159
3/8	1238	637	566	318	849	2159
27/64	1093	562	500	281	749	1905
7/16	969	498	443	249	665	1689
1/2	892	459	408	229	611	1554
9/16	796	409	364	205	546	1388

**BEST PRACTICE ADVICE**

GUIDELINE PARAMETERS ONLY - Actual parameters may vary depending on operating conditions

1. Follow guidelines to set correct RPM speed. Incorrect RPM can lead to poor life or tool breakage
2. Apply firm, steady feed pressure throughout the cut, applying the feed very slowly and cautiously during the first 1mm of cut
3. Avoid lateral movement or tilting which can cause damage to the tool
4. Ensure regular application of quality cooling lubricant, especially when drilling thick or hardened materials
5. Hardened or heat-affected materials may require higher torque, reduced RPM and feed rates and extra coolant
6. VersaDrive<sup>®</sup> Drill Bits up to 10mm diameter can be driven by an Impact Wrench

**QUICK GUIDE**

- Optimum life and performance when used with Rotary Pistol Drills
- Up to 10mm can be used on Impact Wrench & Impact Drivers for fast cutting performance
- Suitable for harder materials such as stainless steel when used at reduced RPM
- Use appropriate lubrication and correct RPM to achieve long tool life

**MORE INFO**



**BEST PRACTICE ADVICE**

GUIDELINE PARAMETERS ONLY - Actual parameters may vary depending on operating conditions

1. Follow guidelines to set correct RPM speed. Incorrect RPM can lead to poor life or tool breakage
2. Apply firm, steady feed pressure throughout the cut, applying the feed very slowly and cautiously during the first 1mm of cut
3. Avoid lateral movement or tilting which can cause damage to the tool
4. Ensure regular application of quality cooling lubricant, especially when drilling thick or hardened materials
5. Hardened or heat-affected materials may require higher torque, reduced RPM and feed rates and extra coolant
6. VersaDrive<sup>®</sup> TurboTips can be used without piloting at all sizes

**QUICK GUIDE**

- For fastest performance use on Impact Wrenches & Impact Drivers
- For optimum life and accuracy use with Pistol Drills and Magnet Drills
- Suitable for use on standard construction grade steels such as Structural or Stainless Steel
- To achieve the best lifespan in Stainless Steel, use with Rotary tools at reduced RPM
- Use appropriate lubrication and correct RPM to achieve long tool life

**MORE INFO**



Diameter	Impact Torque			Impact Torque			Structural Steel <500 Mpa	Structural Steel <1000 Mpa	Stainless Steel INOX	Brass	Cast Iron (Grey)	Plastics	Aluminium
	6mm Thick Steel	12mm Thick Steel	25mm Thick Steel	1/4" Thick Steel	1/2" Thick Steel	1" Thick Steel	32m/Min	18m/Min	12m/Min	32m/Min	16m/Min	30m/Min	45m/Min
	Nm Torque			Ft Lb Torque			RPM Range						
6mm	140	170	280	104	126	207	2040	1070	710	1820	1045	1630	2850
7mm	160	195	300	119	144	222	1780	1020	625	1560	810	1410	2240
8mm	220	270	380	163	200	281	1580	840	550	1340	725	1220	1765
9mm	295	360	520	219	267	385	1210	750	420	1130	600	1040	1550
10mm	320	395	580	237	293	430	1030	520	385	1020	550	990	1480
11mm	325	405	595	241	300	441	980	500	345	960	490	950	1365
12mm	350	430	635	259	319	470	860	440	310	825	405	860	1280
13mm	370	445	675	274	330	500	720	390	260	730	385	745	1160
14mm	375	455	690	278	337	511	660	350	225	665	340	620	950
16mm	455	580	880	337	430	652	535	290	200	610	310	510	875
18mm	580	720	1120	430	533	830	490	245	190	580	275	440	800
20mm	685	845	1245	507	626	922	450	220	175	550	240	350	730
22mm	720	900	1360	533	667	1007	340	180	160	510	210	330	645
3/16"	120	150	220	89	111	163	2270	1135	750	2215	1290	1910	3340
#7	125	155	240	93	115	178	2250	1100	745	2100	1220	1800	3100
7/32"	135	160	260	100	119	193	2125	1095	730	1980	1125	1710	3020
1/4"	150	180	290	111	133	215	1945	1040	680	1715	940	1540	2625
9/32"	175	220	320	130	163	237	1710	985	595	1410	785	1355	2110
5/16"	190	245	350	141	181	259	1695	915	570	1355	760	1290	1940
11/32"	260	330	470	193	244	348	1390	800	515	1435	660	1200	1660
3/8"	300	375	545	222	278	404	1140	665	400	1095	590	1020	1510
27/64"	330	410	610	244	304	452	925	480	330	890	465	915	1320
7/16"	340	420	625	252	311	463	895	455	320	845	430	890	1305
1/2"	365	440	650	270	326	481	780	410	375	780	400	805	1210
17/32"	370	445	675	274	330	500	720	390	260	730	385	745	1160
9/16"	375	455	690	278	337	511	660	350	225	665	340	620	950
5/8"	455	580	880	337	430	652	535	290	200	610	310	510	875
11/16"	580	720	1120	430	533	830	490	245	190	580	275	440	800
3/4"	685	845	1245	507	626	922	450	220	175	550	240	350	730
13/16"	720	900	1360	533	667	1007	340	180	160	510	210	330	645

Impact Torque recommendations are the minimum required and for most applications additional torque is a benefit



Step Drill Diameter	Impact Torque		Structural Steel <500 Mpa	Structural Steel <1000 Mpa	Stainless Steel INOX	Aluminium	Cast Iron (Grey)	Plastics
	Nm Torque	Ft Lbs Torque	RPM Range					
<b>Metric</b>								
3-12mm	280	185	3100-1200	2000-740	1000-380	3100-1200	1300-450	1800-650
14-22mm	400	270	597-430	390-270	200-145	600-440	245-180	380-275
24-30mm	485	350	420-330	260-215	140-110	420-330	175-135	275-180
32-40mm	750	590	260-230	160-145	85-75	260-230	95-85	150-140

Step Drill Diameter	Impact Torque		Structural Steel <500 Mpa	Structural Steel <1000 Mpa	Stainless Steel INOX	Aluminium	Cast Iron (Grey)	Plastics
	Nm Torque	Ft Lbs Torque	RPM Range					
<b>Inch</b>								
3/16-1/2"	280	185	3100-1200	2000-740	1000-380	3100-1200	1300-450	1800-650
3/16-7/8"	400	270	597-430	390-270	200-145	600-440	245-180	380-275
1/4-1-3/8"	540	405	420-330	260-215	140-110	420-330	175-135	275-180

Impact Torque recommendations are the minimum required and for most applications additional torque is a benefit

**BEST PRACTICE ADVICE**

GUIDELINE PARAMETERS ONLY - Actual parameters may vary depending on operating conditions

1. Follow guidelines to set correct RPM speed. Incorrect RPM can lead to poor life or tool breakage
2. Apply firm, steady feed pressure throughout the cut, applying the feed very slowly and cautiously during the first 1mm of cut
3. Avoid lateral movement or tilting which can cause damage to the tool
4. Ensure regular application of quality cooling lubricant, especially when drilling thick or hardened materials
5. Hardened or heat-affected materials may require higher torque, reduced RPM and feed rates and extra coolant
6. When drilling into box section ensure the tip of the Step-Drill is not contacting the far side of the box section at the same time it is drilling the outside wall. This may cause breakage to the tool

**QUICK GUIDE**

- For fastest performance use on Impact Wrenches & Impact Drivers
- Excellent life and performance when used with Rotary Pistol Drills or Pillar Drills
- Suitable for stainless and harder materials if used at low RPM
- Use appropriate lubrication and correct RPM to achieve long tool life

**MORE INFO**



Diameter	Impact Torque		Structural Steel <500 Mpa	Structural Steel <1000 Mpa	Stainless Steel INOX	Brass	Cast Iron (Grey)	Aluminium
	<12mm Thick Steel	<1/2" Thick Steel	32m/Min	18m/Min	12m/Min	32m/Min	16m/Min	45m/Min
	Nm Torque	Ft Lb Torque	RPM Range					
<b>Metric</b>								
8mm	200	160	940	540	410	1020	550	1365
10mm	220	175	900	510	380	1005	530	1290
12mm	280	185	875	490	370	995	520	1200
14mm	320	220	690	360	305	700	500	1100
16mm	340	260	640	335	225	660	340	920
18mm	360	270	535	290	210	550	305	800
20mm	380	285	490	230	195	510	250	745
22mm	400	300	460	210	180	470	235	690
24mm	520	385	360	150	140	430	215	490
26mm	545	405	310	140	135	375	200	400
32mm	575	430	290	130	125	340	180	355

Diameter	Impact Torque		Structural Steel <500 Mpa	Structural Steel <1000 Mpa	Stainless Steel INOX	Brass	Cast Iron (Grey)	Aluminium
	<12mm Thick Steel	<1/2" Thick Steel	32m/Min	18m/Min	12m/Min	32m/Min	16m/Min	45m/Min
	Nm Torque	Ft Lb Torque	RPM Range					
<b>Inch</b>								
1/2"	300	205	875	490	370	520	510	1185
9/16"	330	235	690	360	305	450	450	1025
5/8"	335	250	640	335	225	340	340	975
11/16"	350	265	535	290	210	305	305	860
3/4"	370	280	490	230	195	250	280	745
7/8"	425	310	460	210	180	235	235	675
15/16"	460	380	360	150	140	215	215	540
1"	530	390	310	140	135	200	200	410
1-1/16"	575	440	295	130	125	190	385	380

Impact Torque recommendations are the minimum required and for most applications additional torque is a benefit

**BEST PRACTICE ADVICE**

GUIDELINE PARAMETERS ONLY - Actual parameters may vary depending on operating conditions

1. Follow guidelines to set correct RPM speed. Incorrect RPM can lead to poor life or tool breakage
2. Apply firm, steady feed pressure throughout the cut, applying the feed very slowly and cautiously during the first 1mm of cut
3. Avoid lateral movement or tilting which can cause damage to the tool
4. Ensure regular application of quality cooling lubricant, especially when drilling thick or hardened materials
5. Hardened or heat-affected materials may require higher torque, reduced RPM and feed rates and extra coolant
6. When drilling into box section ensure the tip of the tool is not contacting the far side of the box section at the same time it is drilling the outside wall. This may cause breakage to the tool
7. Flame cut, laser cut or punched holes may not be possible to ream with Impact Wrench. In this situation ream with a slow speed Magnet Drill with a Reamer.

**QUICK GUIDE**

- For fastest performance use on Impact Wrenches & Impact Drivers
- Excellent life and performance when used with Rotary Pistol Drills or Pillar Drills
- Suitable for stainless and harder materials if used at low RPM
- Use appropriate lubrication and correct RPM to achieve long tool life

**MORE INFO**







Thread Diameter	Impact Tapping Torque			Impact Tapping Torque			Structural Steel	Structural Steel	Stainless Steel	Aluminium	Cast Iron (Grey)
	6mm Steel	12mm Steel	25mm Steel	1/4" Steel	1/2" Steel	1" Steel	<500 Mpa	<1000 Mpa	INOX		
	Nm Torque			Ft Lbs Torque			RPM Range				
<b>Metric Coarse</b>											
M3	105	160	N/A	80	120	N/A	960	809	650	2700	1295
M4	120	180	N/A	90	135	N/A	730	610	490	2060	975
M5	135	200	N/A	100	150	N/A	585	485	385	1750	780
M6	140	240	400	105	180	N/A	485	405	325	1455	650
M8	150	280	430	115	210	330	365	310	245	1095	485
M10	170	300	480	125	220	360	295	245	195	870	390
M12	185	320	512	135	235	400	240	200	162	730	330
M14	190	340	544	140	250	400	210	175	140	625	275
M16	200	360	576	150	265	425	185	155	125	550	243
M20	315	400	640	235	300	470	145	125	100	440	194
M24	N/A	600	960	N/A	440	720	120	100	85	370	165
M27	N/A	740	1184	N/A	545	875	105	90	75	330	145
M30	N/A	800	1200	N/A	590	885	95	80	60	310	130
<b>Inch</b>											
1/4"	145	255	410	105	180	295	485	405	325	1455	650
5/16"	145	265	420	110	205	320	365	310	245	1095	485
3/8"	165	290	440	125	220	355	295	245	195	870	390
1/2"	190	330	525	135	235	375	240	200	162	730	330
5/8"	195	355	555	145	265	425	185	155	125	550	243
3/4"	245	385	615	230	295	470	145	125	100	440	194
7/8"	N/A	515	775	N/A	370	710	130	115	92	410	180
1"	N/A	695	1050	N/A	445	735	120	100	85	370	165

Impact Torque recommendations are the minimum required and for most applications additional torque is a benefit

### BEST PRACTICE ADVICE

GUIDELINE PARAMETERS ONLY - Actual parameters may vary depending on operating conditions

1. ImpactaTaps are recommended for through hole applications only
2. Pilot drill the exact tapping size hole for best results
3. Select the correct torque for Impact tools using the table above. If exact match is not available select the closest torque setting above the recommendation
4. Apply firm, steady feed pressure throughout the cut
5. Ensure the Tap is inserted squarely to the hole - poorly aligned or off-centre taps will greatly increase the risk of breakage
6. Regularly apply quality cooling lubricant, especially when drilling thick or hardened materials
7. Hardened or heat-affected materials may require higher torque, reduced RPM and feed rates and extra coolant
8. Flame cut/punched holes will require more torque to tap than drilled holes due to heat build up. Caution: Sometimes flame cut holes do not have parallel sides meaning risk of tap breakage
9. Tap the hole in one pass where possible, applying adequate lubrication before you start.
10. If the tap is over-run from the hole once it is tapped, to remove the risk of cross-threading/damage to the tap, remove the tap from the adapter and locate it in the thread by hand, before reversing
11. When using cordless tools, torque may drop once the battery charge becomes low. Keep batteries well charged. Low battery charge can lead to lower torque which can break or damage taps as point 3
12. When re-threading an existing thread, use caution to avoid cross-threading which can lead to tap breakage or thread damage. It is advisable to insert/start the tap into the thread by hand before driving it through at the correct torque

### QUICK GUIDE

- For fastest performance use on Impact Wrenches & Impact Drivers
- Check the minimum torque requirement
- Laser cut holes & Stainless Steel require higher torque
- Use appropriate lubrication and correct RPM to achieve long tool life

### MORE INFO



### BEST PRACTICE ADVICE

GUIDELINE PARAMETERS ONLY - Actual parameters may vary depending on operating conditions

1. Spiral Flute ImpactaTaps are primarily recommended for blind hole applications using a clutched adapter to prevent the Tap from breaking when it reaches the bottom of the hole (See page 42)
2. Pilot drill the exact tapping size hole for best results
3. Select the correct Impact Torque or RPM (Rotary mode) for drive tools using the table above.
4. Apply firm, steady feed pressure throughout the cut
5. Ensure the Tap is inserted squarely to the hole - poorly aligned or off-centre taps will greatly increase the risk of breakage
6. Regularly apply quality cooling lubricant, especially when drilling thick or hardened materials
7. Hardened or heat-affected materials may require higher torque, reduced RPM and feed rates and extra coolant
8. When re-threading an existing thread, use caution to avoid cross-threading which can lead to tap breakage or thread damage. It is advisable to insert/start the tap into the thread by hand before driving it through at the correct torque

### QUICK GUIDE

- For fastest performance use on Impact Wrenches & Impact Drivers
- Check the minimum torque requirement
- Laser cut holes & Stainless Steel require higher torque
- Use appropriate lubrication and correct RPM to achieve long tool life

### MORE INFO





Metric	Thread Diameter	Max Material Thickness	Impact Torque		Structural Steel				
			Nm	Ft Lbs	<500 Mpa		Stainless Steel INOX	Aluminium	Cast Iron (Grey)
					RPM	RPM			
M3	3mm		105	80	960	810	650	2700	1295
M4	4mm		120	90	730	610	490	2060	975
M5	5mm		135	100	585	485	385	1750	780
M6	6mm		140	105	485	405	325	1455	650
M8	8mm		150	115	365	310	245	1095	485
M10	10mm		170	125	295	245	195	870	390
M12	12mm		320	235	240	200	160	730	330

Inch (UNC)	Thread Diameter	Max Material Thickness	Impact Torque		Structural Steel				
			Nm	Ft Lbs	<500 Mpa		Stainless Steel INOX	Aluminium	Cast Iron (Grey)
					RPM	RPM			
4-40	3/32"		105	75	1050	850	710	2900	1390
6-32	1/8"		120	90	950	790	650	2700	1295
8-32	5/32"		135	95	730	610	490	2060	975
10-24	13/64"		135	100	595	475	395	1700	820
1/4-20	1/4"		135	105	485	405	325	1455	650
5/16-18	5/16"		280	110	365	310	245	1095	485
3/8-16	3/8"		300	120	295	245	195	870	390
1/2-13	1/2"		320	235	240	200	160	730	330

Impact Torque recommendations are the minimum required and for most applications additional torque is a benefit

**BEST PRACTICE ADVICE**

GUIDELINE PARAMETERS ONLY - Actual parameters may vary depending on operating conditions

1. Impact DrillTaps are recommended for through hole applications only
2. Pilot drill the exact tapping size hole for best results
3. Select the correct torque for Impact tools using the table above. If exact match is not available select the closest torque setting above the recommendation
4. Apply firm, steady feed pressure throughout the cut
5. Ensure the Tap is inserted squarely to the hole - poorly aligned or off-centre taps will greatly increase the risk of breakage
6. Regularly apply quality cooling lubricant, especially when drilling thick or hardened materials
7. Hardened or heat-affected materials may require higher torque, reduced RPM and feed rates and extra coolant
8. Tap the hole in one pass where possible, applying adequate lubrication before you start.
9. Sheet Metal Drill-Taps are intended for tapping material no greater than the tap diameter

**QUICK GUIDE**

- For fastest performance use on Impact Wrenches
- Check the minimum torque requirement
- Up to M10 (3/8") can also be used on cordless drills

**MORE INFO**



Metric	Thread Diameter	Impact Torque		Structural Steel				
		Nm	Ft Lbs	<500 Mpa		Stainless Steel INOX	Aluminium	Cast Iron (Grey)
				RPM	RPM			
M8		280	205	365	310	245	1095	485
M10		320	220	295	245	195	870	390
M12		340	235	240	200	160	730	330
M16		550	425	185	155	125	550	240
M20		700	475	145	125	100	440	195
M24		960	630	120	100	85	370	165

Inch (UNC)	Thread Diameter	Impact Torque		Structural Steel				
		Nm	Ft Lbs	<500 Mpa		Stainless Steel INOX	Aluminium	Cast Iron (Grey)
				RPM	RPM			
1/2-13		340	235	240	200	160	730	330
5/8-11		550	365	185	155	125	550	240
3/4-10		700	675	145	125	100	440	195
1-8		960	735	120	100	85	370	165

Impact Torque recommendations are the minimum required and for most applications additional torque is a benefit

**BEST PRACTICE ADVICE**

GUIDELINE PARAMETERS ONLY - Actual parameters may vary depending on operating conditions

1. Impact DrillTaps are recommended for through hole applications only
2. Pilot drill the exact tapping size hole for best results
3. Select the correct torque for Impact tools using the table above. If exact match is not available select the closest torque setting above the recommendation
4. Apply firm, steady feed pressure throughout the cut
5. Ensure the Tap is inserted squarely to the hole - poorly aligned or off-centre taps will greatly increase the risk of breakage
6. Regularly apply quality cooling lubricant, especially when drilling thick or hardened materials
7. Hardened or heat-affected materials may require higher torque, reduced RPM and feed rates and extra coolant
8. Tap the hole in one pass where possible, applying adequate lubrication before you start.
9. When tapping material thicker than 15-20mm, to speed up the process it is advisable to pilot drill the hole first, before drill tapping the hole
10. Heavy Duty Drill Taps are designed for use with Magnet Drills/Pillar Drills, or for tapping pre-drilled holes with an Impact Wrench. They are not designed for drill-tapping with hand-held rotary tools

**QUICK GUIDE**

- Ideal for use in Pillar Drills & Magnet Drills
- Correct RPM is critical for good performance on larger sizes
- For Impact Wrench use, pilot drilling is recommended

**MORE INFO**





Countersink Diameter	Structural Steel <500 Mpa	Structural Steel <1000 Mpa	Stainless Steel INOX	Aluminium	Cast Iron (Grey)	Plastics
12.4mm	385	255	110	635	265	480
16.5mm	295	185	80	485	210	345
20.5mm	230	155	50	385	165	280
25mm	185	130	50	315	130	225
31mm	155	105	35	265	105	185

Refer to Page 114 for Pilot Hole Drilling Speeds

**BEST PRACTICE ADVICE**

**GUIDELINE PARAMETERS ONLY** - Actual parameters may vary depending on operating conditions

1. Use with a variable speed motor. Drill and countersink operations should be run at the appropriate speed for each process
2. Apply firm, steady feed pressure throughout the cut
3. Avoid lateral movement or tilting which can cause damage to the tool
4. Ensure regular application of quality cooling lubricant, especially when drilling thick or hardened materials
5. Hardened or heat-affected materials may require higher torque, reduced RPM and feed rates and extra coolant
6. Ensure a debris free surface of sufficient steel thickness for strong magnet hold when Magnet Drilling
7. Use at highest available Gear setting (for maximum torque).
8. Best countersinking results are achieved using a variable speed drill that allows the correct speed to be set
9. Piloted Countersink Bits (like the MultiSink) will significantly increase countersinking performance preventing movement of the countersink whilst drilling
10. Follow guidelines to set correct RPM speed. Incorrect RPM can lead to poor life or tool breakage

**QUICK GUIDE**

- Optimum life and performance when used with Rotary Pistol Drills or Pillar Drills
- Up to 16.5mm can be used on Impact Wrench & Impact Drivers for fast cutting performance
- Suitable for harder materials such as stainless steel when used at reduced RPM
- Use appropriate lubrication and correct RPM to achieve long tool life

**MORE INFO**



Countersink Diameter	Structural Steel <500 Mpa	Structural Steel <1000 Mpa	Stainless Steel INOX	Aluminium	Cast Iron (Grey)	Plastics	
							RPM Range
<b>Metric</b>	6.3mm	765	505	265	1250	500	850
	8.3mm	535	355	195	865	340	585
	10.4mm	460	300	145	765	315	530
	12.4mm	385	255	110	635	265	480
	16.5mm	295	185	80	485	210	345
	20.5mm	230	155	50	385	165	280
	25mm	185	130	50	315	130	225
<b>Inch</b>	31mm	155	105	35	265	105	185
	1/4"	765	505	265	1250	500	850
	3/8"	460	300	145	765	315	530
	1/2"	385	255	110	635	265	480
	5/8"	295	185	80	485	210	345
	3/4"	230	155	50	385	165	280
1"	185	130	50	315	130	225	

**BEST PRACTICE ADVICE**

**GUIDELINE PARAMETERS ONLY** - Actual parameters may vary depending on operating conditions

1. Follow guidelines to set correct RPM speed. Incorrect RPM can lead to poor life or tool breakage
2. Apply firm, steady feed pressure throughout the cut
3. Avoid lateral movement or tilting which can cause damage to the tool
4. Ensure regular application of quality cooling lubricant, especially when drilling thick or hardened materials
5. Hardened or heat-affected materials may require higher torque, reduced RPM and feed rates and extra coolant
6. Ensure a debris free surface of sufficient steel thickness for strong magnet hold when Magnet Drilling
7. Use at highest available Gear setting (for maximum torque)
8. Best countersinking results are achieved using a variable speed drill that allows the correct speed to be set

**QUICK GUIDE**

- Optimum life and performance when used with Magnet Drills or Pillar Drills
- Up to 16.5mm can be used on Impact Wrench & Impact Drivers for fast cutting performance
- Suitable for harder materials such as stainless steel when used at reduced RPM
- Use appropriate lubrication and correct RPM to achieve long tool life

**MORE INFO**







Diameter	Impact Torque		Impact Torque		Structural Steel <500 Mpa	Structural Steel <1000 Mpa	Stainless Steel INOX	Brass	Cast Iron (Grey)	Aluminium	
	<12mm Thick Steel	>25mm Thick Steel	<1/2" Thick Steel	<1" Thick Steel							
	Nm		Ft Lb								
	RPM Range										
<b>Metric</b>	8mm	200	380	160	290	940	540	410	1020	550	1365
	10mm	220	400	175	300	900	510	380	1005	530	1290
	12mm	280	420	185	305	875	490	370	995	520	1200
	14mm	320	480	220	330	690	360	305	700	500	1100
	16mm	340	510	260	390	640	335	225	660	340	920
	18mm	360	540	270	410	535	290	210	550	305	800
	20mm	380	570	285	425	490	230	195	510	250	745
	21mm	390	580	290	430	480	225	190	500	240	710
	22mm	400	600	300	435	460	210	180	470	235	690
	24mm	520	780	385	600	360	150	140	430	215	490
	26mm	650	1000	405	640	310	140	135	375	200	400
	28mm	720	1080	480	750	295	130	125	340	190	360
	30mm	780	1365	520	785	275	120	110	290	180	330
	32mm	940	1410	545	820	250	110	100	275	170	305
	33mm	970	1440	560	840	240	105	95	270	165	295
	36mm	1030	1520	600	870	215	95	80	255	150	255
	39mm	1260	1610	720	920	195	80	65	240	135	220
	41mm	1340	1736	750	965	185	75	60	220	125	200
<b>Inch</b>	1/2"	300	445	205	310	875	490	370	520	510	1185
	9/16"	330	490	235	355	690	360	305	450	450	1025
	5/8"	335	505	250	375	640	335	225	340	340	975
	11/16"	350	525	265	400	535	290	210	305	305	860
	3/4"	370	560	280	420	490	230	195	250	280	745
	7/8"	425	630	310	440	460	210	180	235	235	675
	15/16"	460	695	380	575	360	150	140	215	215	540
	1"	530	805	390	620	310	140	135	200	200	410
	1-1/16"	575	875	440	660	295	130	125	190	385	380
	1-3/16"	780	1365	520	785	275	120	110	290	180	330
	1-5/16"	970	1440	560	840	240	105	95	270	165	295
	1-3/8"	1030	1520	600	870	240	105	95	270	165	295
	1-7/16"	1030	1520	600	870	240	105	95	270	165	295
	1-1/2"	1260	1610	720	920	195	80	65	240	135	220
	1-9/16"	1260	1610	720	920	195	80	65	240	135	220
	1-5/8"	1340	1736	750	965	185	75	60	220	125	200

Metric Countersink Diameter	Structural Steel <500 Mpa	Structural Steel <1000 Mpa	Stainless Steel INOX	Aluminium	Cast Iron (Grey)	Plastics
	RPM Range					
30mm	155	105	35	265	105	185
40mm	120	80	30	205	80	140
55mm	95	60	25	145	70	120
63mm	80	55	20	130	55	90
80mm	65	40	20	100	45	75
Inch Countersink Diameter	Structural Steel <500 Mpa	Structural Steel <1000 Mpa	Stainless Steel INOX	Aluminium	Cast Iron (Grey)	Plastics
RPM Range						
1-1/4"	155	105	35	265	105	185
1-1/2"	120	80	30	205	80	140
2"	95	60	25	145	70	120
2-1/4"	90	55	20	140	65	115

### BEST PRACTICE ADVICE

GUIDELINE PARAMETERS ONLY - Actual parameters may vary depending on operating conditions

1. Apply firm, steady feed pressure throughout the cut, applying feed very slowly & cautiously during the first 1mm of cut
2. Avoid lateral movement or tilting which can cause damage to the tool
3. Do not attempt to increase the existing hole diameter beyond 2-3mm. If a larger, finished hole size is required, use the next size reamer to 'step up' until the finished hole diameter is reached.
4. Ensure regular application of quality cooling lubricant, especially when drilling thick or hardened materials
5. Follow guidelines to set correct RPM speed. Incorrect RPM can lead to poor life or tool breakage
6. Flame cut, laser cut or punched holes may not be possible to ream with Impact Wrenches. In this situation ream with a slow speed Magnet Drill
7. Ensure a debris free surface of sufficient steel thickness for strong magnet hold when Magnet Drilling.
8. Regularly check that Magnet Drill slides, handles, arbors and movable parts have not vibrated loose over time.

### QUICK GUIDE

- For fastest performance use on Impact Wrenches & Impact Drivers
- Check the minimum torque requirement
- Reamer should be rotating before starting the cut
- Use steady feed pressure throughout the cut

### MORE INFO



### BEST PRACTICE ADVICE

GUIDELINE PARAMETERS ONLY - Actual parameters may vary depending on operating conditions

1. Follow guidelines to set correct RPM speed. Incorrect RPM can lead to poor life or tool breakage
2. Apply firm, steady feed pressure throughout the cut
3. Avoid lateral movement or tilting which can cause damage to the tool
4. Ensure regular application of quality cooling lubricant, especially when drilling thick or hardened materials
5. Hardened or heat-affected materials may require higher torque, reduced RPM and feed rates and extra coolant
6. Ensure a debris free surface of sufficient steel thickness for strong magnet hold when Magnet Drilling
7. Use at highest available Gear setting (for maximum torque)
8. Best countersinking results are achieved using a variable speed drill that allows the correct speed to be set
9. Piloted Countersink Bits (like the MultiSink) will significantly increase countersinking performance preventing movement of the countersink whilst drilling

### QUICK GUIDE

- Optimum life and performance when used with Magnet Drills or Pillar Drills
- Up to 16.5mm can be used on Impact Wrench & Impact Drivers for fast cutting performance
- Suitable for harder materials such as stainless steel when used at reduced RPM
- Use appropriate lubrication and correct RPM to achieve long tool life

### MORE INFO





Diameter	Structural Steel <500 Mpa Based on mm/R Feed of 0.10	Structural Steel <1000 Mpa Based on mm/R Feed of 0.10	Stainless Steel INOX Based on mm/R Feed of 0.13	Aluminium	Cast Iron (Grey)	Fibreglass	Composite	Plastics	Wood
	RPM Range								
13-17mm	1350-850	840-585	500-360	2210-1575	900-625	780-705	1350-850	900-640	1495-1010
18-25mm	850-625	580-420	350-250	1575-1125	600-455	700-520	850-625	620-450	990-895
26-31mm	620-500	415-325	240-195	1080-885	435-345	500-405	620-500	440-345	895-850
32-39mm	480-410	320-275	195-160	875-740	330-285	400-330	480-410	345-280	850-740
40-46mm	390-340	270-220	160-145	730-620	285-240	315-275	390-340	175-235	740-610
47-53mm	335-300	220-180	140-120	615-545	235-215	275-245	335-300	235-215	600-505
54-60mm	295-260	180-165	115-100	525-485	210-180	240-215	295-260	210-185	500-460
61-70mm	260-225	165-155	100-90	475-415	180-160	205-185	260-225	180-160	455-400
71-80mm	220-195	155-140	90-75	410-365	155-140	180-160	220-195	155-140	395-360

Diameter	Structural Steel <500 Mpa (S275, S355) Based on mm/R Feed of 0.10	Structural Steel <1000 Mpa Based on mm/R Feed of 0.10	Stainless Steel INOX Based on mm/R Feed of 0.13	Cast Iron-Grey	Aluminium
	RPM Range				
12-19mm	1265-850	850-580	530-350	925-615	2200-1560
20-25mm	840-650	550-410	345-255	610-440	1480-1140
26-32mm	545-460	410-315	250-200	430-335	1125-890
33-39mm	460-395	315-265	195-170	330-280	885-730
40-46mm	405-340	265-250	165-140	280-235	720-620
47-53mm	335-300	250-195	135-120	235-205	615-545
54-60mm	295-265	195-180	120-105	200-180	540-475
61-70mm	260-230	180-140	105-90	180-160	475-415
71-80mm	230-200	140-130	90-70	160-145	410-365
81-90mm	195-180	130-115	70-65	140-125	350-325
91-100mm	180-160	115-100	60-55	125-110	320-280
101-112mm	160-140	100-90	55-50	110-100	280-250
113-124mm	140-120	90-85	50-48	100-90	250-235
125-136mm	120-110	85-75	48-45	90-80	230-205
137-150mm	110-100	70-65	45-40	80-75	205-190
151 - 174mm	70 - 80	50 - 60	45 - 40	55 - 65	145 - 155
175 - 200mm	60 - 70	40 - 50	25 - 30	45 - 55	120 - 140

**BEST PRACTICE ADVICE**

GUIDELINE PARAMETERS ONLY - Actual parameters may vary depending on operating conditions

1. Centre punch or pilot drill the surface for accurate hole start
2. Follow guidelines to set correct RPM speed. Incorrect RPM can lead to poor life or tool breakage
3. Apply firm, steady feed pressure throughout the cut, applying the feed very slowly and cautiously during the first 1mm of cut
4. Avoid lateral movement or tilting which can cause damage to the tool
5. Ensure regular application of quality cooling lubricant, especially when drilling thick or hardened materials
6. Hardened or heat-affected materials may require higher torque, reduced RPM and feed rates and extra coolant
7. When using a Magnet Drill regularly check that slides, handles, arbors and movable parts have not vibrated loose over time
8. Ensure a debris free surface of sufficient steel thickness for strong magnet hold when Magnet Drilling
9. For drilling holes in steel thicker than 25mm it is recommended to ventilate the hole frequently to clear the swarf
10. For thicker materials, predrill 6.35mm pilot hole first and use then sprung pilot drill or pilot pin as a guide

**QUICK GUIDE**

- Optimum life & performance when used with Rotary Pistol Drills
- Good results from SDS Drills when used in Rotary-Only mode
- For best results pre-drill the pilot hole
- Use appropriate lubrication and correct RPM to achieve long tool life

**MORE INFO**



**BEST PRACTICE ADVICE**

GUIDELINE PARAMETERS ONLY - Actual parameters may vary depending on operating conditions

1. Centre punch or pilot drill the surface for accurate hole start
2. Follow guidelines to set correct RPM speed. Incorrect RPM can lead to poor life or tool breakage
3. Apply firm, steady feed pressure throughout the cut, applying the feed very slowly and cautiously during the first 1mm of cut
4. Avoid lateral movement or tilting which can cause damage to the cutter
5. Ensure regular application of quality cooling lubricant, especially when drilling thick or hardened materials
6. Hardened or heat-affected materials may require higher torque, reduced RPM and feed rates and extra coolant
7. Regularly check that Magnet Drill slides, handles, arbors and movable parts have not vibrated loose over time
8. Ensure a debris free surface of sufficient steel thickness for strong magnet hold when Magnet Drilling
9. For drilling holes in steel thicker than 25mm it is recommended to ventilate the hole frequently to clear the swarf
10. Selecting the correct machine will often result in better life from the consumables and a quicker completion of the task

**QUICK GUIDE**

- Adjust RPM to match the material
- Slowly and cautiously begin cutting before increasing pressure
- For best results & swarf clearance always select a cutter longer than the material thickness
- For hard materials & wear plates like Hardox use Ultra coated cutters. See page 68-73

**MORE INFO**





Metric Diameter (mm)	Hard Material c. 450 Brinell	
	RPM (No Load) Based on 8.0 m/min	
4		530
5		480
6		424
7		370
8		318
9		286
10		255
11		235
12		212
13		195
14		182

Inch Diameter (")	Hard Material c. 450 Brinell	
	RPM (No Load) Based on 8.0 m/min	
1/4		424
9/32		370
5/16		318
3/8		255
1/2		212
9/16		182



Metric Diameter (mm)	Hard Material c. 450 Brinell	
	RPM (No Load) Based on 18.0 m/min	
16		358
18		318
20		286
22		260
24		239
26		220
28		205
30		191
32		179
34		169
36		159

Inch Diameter (")	Hard Material c. 450 Brinell	
	RPM (No Load) Based on 18.0 m/min	
5/8		358
11/16		318
3/4		286
13/16		260
7/8		260
15/16		239
1		220



Countersink	Diameter	Hard Material c. 450 Brinell	
		RPM (No Load)	
Ultra Countersink	32mm (1-1/4")		80 - 140
Ultra MultiSink	40mm (1-1/2")		80 - 140
Ultra MultiSink	55mm (2-1/4")		60 - 100

BEST PRACTICE ADVICE

GUIDELINE PARAMETERS ONLY - Actual parameters may vary depending on operating conditions

ULTRA Cutting Tools are designed for the Machining of Armor and Wear Plates such as HARDOX - CREUSABRO - ABRO - RAEX - STRENX - BISALLOY

1. The extreme hardness and resistance of wear plate makes machining it extremely challenging.
2. Good results are dependent on the right setup - including high torque/slow speed, geared Magnet Drills, such as the VersaDrive<sup>®</sup> V125T, and correct lubrication
3. Using an incorrect or poorly maintained Magnet Drill with unstable drilling operation, poor magnet hold, excessive pressure or inadequate lubrication is likely to result in rapid tool failure.
4. Even with high tech tooling, successfully machining Wear plates is challenging with little or no margin for error. It not only requires the correct setup but also experienced operators with the time necessary to proceed with caution.
5. Feed should be applied constantly, do not allow the drill to dwell as the material will work harden (if a rest or repositioning of hands is required, then retract the cutting tool slightly off the material first)
6. When drilling hard materials drill required hole size in one operation - do not attempt to pilot drill & step up through drill sizes
7. When cutting, any rubbing of the cutting tool must be avoided as it will increase the surface hardness, as wear plate material is designed to 'work-harden' to combat wear and abrasion
8. When using a 2-Geared Speed or 4-Geared Speed drilling machine, the lower gear speeds provide the most torque
9. When using the electronic variable speed and torque controls, maximum torque and power is available when both torque and speed are adjusted to their maximum setting
10. Machines fitted with torque control will try to maintain the selected speed and slow slightly, when under load
11. Regular application of lubricant and removal of swarf from the cutting face is essential
12. A hand brush is helpful to keep excess swarf away from the cut
13. Constant coolant application is advisable to carry away any heat generated by cutting, as heat build up can cause work hardening.
14. For best results use the new flood coolant pump with a soluble mix of BioCut Blue lubricant & room temperature tap water.  
Suggested mix: 0.5L of BioCut Blue to 3.5L water
15. If a flood cooling system is used, consider there will be excess coolant spillage
16. For best result when countersinking, the countersink should be piloted where possible - see MultiSink pilots on page 69
17. Do not allow the countersink to vibrate over swarf while cutting as this will cause chatter, ultimately causing the cutting edge to chip & blunt

MORE INFO



Cordless coolant pump  
See page 86





## TOOLING PRODUCT SUPPORT

HMT offer an industry leading warranty system to provide product users and distributors with peace of mind.

### Product Pledge

One of our core values is 'Optimise' and this means helping users get the best out of their HMT & VersaDrive® tooling.

Our products are designed to out-perform any comparable tools in the marketplace. However we live in the real world where no cutting tools are unbreakable and the occasional problem is to be expected.

We utilise tracking software to log and analyse in detail each product issue that is reported. Our statistics show that on average for every 10,000 tools we supply, only 12 tools have to be replaced under warranty, usually under goodwill because the cause of the problem can't be clearly identified as either a defective product or failure caused by user error.

Our Technical staff or sales demonstrators are able to help resolve most product issues either through remote diagnosis or, where possible, a site visit may be appropriate.

## ONLINE TECHNICAL SUPPORT

With customers often using products in remote locations, time sensitive jobs or awkward applications, easy access to technical assistance or warranty support can make the difference between successful, on-time project completion or costly delays.

HMT technical support is available online, ensuring access at all times of day or night and wherever a customer might need it via their phone, tablet or computer.

### Online Support Available

- Product Data Sheets - Comprehensive speed & torque guides
- Best Practice Advice
- Power tool recommendations - Guide to choosing the right tool for the job
- Product FAQ sections - Immediately troubleshoot common issues
- Magnetic drill manuals for online viewing and download
- Magnetic drill safety information and user guidance
- Warranty Support forms - typically actioned same day if possible
- Video demonstrations - YouTube & HMT Online



### The MATLaST Methodology

We have a solid process to assess any complaint and give fast feedback using our 'MATLaS' methodology to assess reported issues.

<b>Material</b>	Material being cut eg S275, S355 etc
<b>Apparatus</b>	Power tool used, model number & battery
<b>Thickness</b>	5mm, 10mm etc
<b>Lubricant</b>	Was lubricant used & if so which one?
<b>Speed/Torque</b>	What speed/torque setting was used?
<b>Traceability</b>	What is the unique batch number?

Having the information above enables us to identify whether product failure was due to a tooling issue that needs further investigation or an application error that can be addressed to ensure the same issues do not occur in the future.

## ONLINE DEALER PORTAL

The HMT Hub is an **online dealer portal**.

Available 24/7, it allows dealers to place orders at any time whilst also providing immediate access to key operational information, activities and advantages such as the below:

- Place orders**
- Access quotes**
- Check pricing & live stock availability**
- View promotions**
- Track shipments**
- Monitor Back Orders**
- View Invoices**
- Access instant acknowledgements**
- Later next-day delivery cut off time of 4pm (Mainland UK)**
- Download PODs**
- No direct delivery charge**  
(direct deliveries ordered outside of the HUB are subject to £5.95 surcharge)
- & more...**



## VersaDrive® Magnet Drill REGISTRATION & WARRANTY FORMS

### Magnet Drill REGISTRATION

Register your 2 year VersaDrive® Magnet Drill warranty by scanning the QR code below and filling in the online registration form.



### CUTTING TOOL WARRANTY

Should you experience an issue with an HMT cutting tool, please scan the QR code below, complete the form with as much information as possible & one of our technical team will review your case and get back to you.



### Magnet Drill WARRANTY

Should you experience an issue with an HMT Magnet Drill, please scan the QR code below, complete the form with as much information as possible & one of our technical team will review your case and get back to you.



**VERSADRIVE®**  
PATENT PROTECTED



**Find your local dealer at**  
[www.holemaker-technology.com](http://www.holemaker-technology.com)  
[sales@holemaker-technology.com](mailto:sales@holemaker-technology.com)

**HOLEMAKER TECHNOLOGY**  
**HMT**

**HMT Head Office:**

Bridge House,  
Pattenden Lane,  
Marden, Kent,  
TN12 9QJ, UK  
UK Landline: 03330 110 382

**HMT Technical Centre:**

Europa House,  
Sheffield Business Park,  
Europa Link,  
Sheffield, S9 1XE, UK  
International: +44 1622 522 102



We reserve the right to modify without prior notification any details stated in the catalogue regarding product features, versions and designs or any prices quoted. All prices shown are subject to UK VAT where applicable.  
No liability for printing errors or mistakes shall be assumed. Terms & Conditions apply, copy available on request.  
Holemaker Technology Ltd, January 2024.